

TECHNICAL MANUAL

**DIRECT SUPPORT AND GENERAL SUPPORT
MAINTENANCE MANUAL
(Including Repair Parts and Special Tools List)**

DEMOLITION MATERIALS

DISTRIBUTION STATEMENT A: Approved for public release; distribution is unlimited.

HEADQUARTERS, DEPARTMENT OF THE ARMY

FEBRUARY 1996

LIST OF EFFECTIVE PAGES

When applicable, insert latest change pages and dispose of superseded pages in accordance with applicable regulations.

**TOTAL NUMBER OF PAGES IN THIS PUBLICATION IS 88
CONSISTING OF THE FOLLOWING:**

<i>Page No.</i>	<i>*Change No.</i>
Cover	0
Inside Cover	0
A and B	0
i and ii	0
1-1 and 1-2	0
2-1 and 2-2	0
3-1 and 3-2	0
4-1 thru 4-36	0
A-1 and A-2	0
B-1 thru B-14	0
C-1 thru C-6	0
D-1 thru D-4	0
Authentication Page	0

* Zero indicates an original page.

THIS PAGE INTENTIONALLY LEFT BLANK

Technical Manual)
)
No. 9-1375-213-34&P)

HEADQUARTERS
DEPARTMENT OF THE ARMY
Washington DC, 29 February 1996

**DIRECT SUPPORT AND GENERAL SUPPORT
MAINTENANCE MANUAL
(Including Repair Parts and Special Tools List)
DEMOLITION MATERIALS**

REPORTING ERRORS AND RECOMMENDING IMPROVEMENTS

You can help improve this manual. If you find any mistakes or if you know of a way to improve the procedures, please let us know. You may mail, e-mail, or FAX your response. Mail your letter, DA Form 2028 (Recommended Changes to Publications and Blank Forms), or DA Form 2028-2 located in the back of this manual direct to: Commander, U.S. Army TACOM, Armament Research, Development and Engineering Center, ATTN: AMSTA-AR-LSB, Picatinny Arsenal, NJ 07806-5000. E-mail address is LSB@PICA.ARMY.MIL. FAX number is Commercial (201) 724-4633, DSN 880-4633. A reply will be furnished to you.

	Page
CHAPTER 1. INTRODUCTION	
Section I. General	
1-1. Scope	1-1
1-2. Forms, Records, and Reports	1-1
Section II. Description and Data	
1-3. General	1-1
Section III. Safety, Care, and Handling	
1-4. General	1-1
CHAPTER 2. TOOLS AND EQUIPMENT	
2-1. General	2-1
2-2. Tools and Equipment	2-1
2-3. Repair Parts	2-1
CHAPTER 3. INSPECTION REQUIREMENTS	
3-1. General	3-1
3-2. Visual Inspection of Incoming Ammunition	3-1
CHAPTER 4. MAINTENANCE PROCEDURES	
4-1. General	4-1
4-2. Direct Support Maintenance	4-1
4-3. General Support Maintenance	4-1

*This manual supersedes TM 9-1375-213-34, 30 March 1973, including all changes.

CHAPTER 4.	MAINTENANCE PROCEDURES - Continued	Page
4-4.	Rust Removal and Touchup	4-1
4-5.	Repainting	4-3
4-6.	Re-marking	4-4
4-7.	Inspecting and Reconditioning Packing Box	4-17
4-8.	Inspecting Barrier Bag	4-17
4-9.	Repacking	4-17
4-10.	Palletizing	4-18
4-11.	Special Procedure for Cleaning and Repacking of 15-pound Shaped Charges	4-20
4-12.	Color Coding Boxes With Light Loads	4-21
4-13.	Blasting Machine Maintenance	4-21
APPENDIX	A. REFERENCES	A-1
	B. DIRECT SUPPORT AND GENERAL SUPPORT MAINTENANCE REPAIR PARTS AND SPECIAL TOOLS LIST	B-1
	C. EXPENDABLE AND DURABLE ITEMS LIST	C-1
	D. PACKING MATERIALS, ACCESSORIES, AND TOOLS	D-1

CHAPTER 1 INTRODUCTION

Section I. GENERAL

1-1. Scope

a. This technical manual describes general and technical information, and inspection and maintenance procedures for demolition materials. Information in this manual covers the responsibilities of direct and general support maintenance personnel (i.e., maintenance which is beyond the scope of the tools, equipment, or supplies normally available to operator and unit personnel).

b. Information for operator and unit maintenance personnel is covered in TM 9-1375-213-12, which includes the Maintenance Allocation Chart (Appendix C). Direct support and general support maintenance responsibilities are specified in the Maintenance Allocation Chart. This manual should be used in conjunction with TM 9-1375-213-12.

c. Field service stocks including basic load will be checked for serviceability as directed by USA Industrial Operations Command (IOC), Rock Island, IL using the inspection and function test procedures of SB 742-1 and the specific supply bulletins and supporting supply bulletins listed in Appendix A under the direction of the cognizant QASAS. The field-expedient methods and equipment detailed in previous editions of this TM are no longer authorized.

1-2. Maintenance Forms, Records, and Reports

Forms generally applicable to units maintaining subject materiel are listed in Appendix A. For a current listing of all forms, refer to DA Pam 25-30. Refer to DA Pam 738-750 for instructions on use and completion of all forms required for maintaining demolition materials.

Section II. DESCRIPTION AND DATA

1-3. General

For detailed description and data of demolition items and accessories, refer to TM 9-1375 213-12.

Section III. SAFETY, CARE, AND HANDLING

1-4. General

For detailed information on safety, care, and handling of demolition items and accessories, refer to TM 9-1375-213-12 and TM 9-1300-206.

THIS PAGE INTENTIONALLY LEFT BLANK

CHAPTER 2

TOOLS AND EQUIPMENT

2-1. General

Tools, equipment, and repair parts in addition to those available to the using organization, are supplied to direct and general support maintenance units for maintaining demolition items and accessories.

2-2. Tools and Equipment

a. Tools and equipment having general application to this materiel are authorized for issue by tables of allowances (TA) and tables of organization and equipment (TOE).

b. Except when otherwise indicated, local fabrication of tools and equipment is not authorized.

c. The standard tool set authorized for the direct support (DS) and general support (GS) ammunition maintenance is NSN 4940-00-322-6058 covered in Supply Catalog 4940-95-A11.

2-3. Repair Parts

Appendix B lists repair parts and Appendix D lists ammunition boxes required by direct support and general support maintenance personnel.

THIS PAGE INTENTIONALLY LEFT BLANK

CHAPTER 3

INSPECTION REQUIREMENTS

3-1. General

a. Ammunition received at DS/GS, ammunition supply point (ASP) will be given a thorough visual inspection for damage to the packaging which could reduce the level of protection it provides to the ammunition or which indicates that the ammunition within the packaging may be damaged. In the latter case, the ammunition will be unpacked only to the lowest level necessary to determine if it has been damaged. The same basic criteria detailed in TM 9-1375-213-12 apply. Undamaged boxes will not be depalletized for this upcoming inspection and undamaged boxes will not be unsealed.

b. Field service stocks, including basic load, will be checked for serviceability as directed by USA IOC, Rock Island, IL using the inspection and function test procedures of SB 742-1 and the specific supply bulletins and supporting supply bulletins listed in Appendix A under the direction of the cognizant QASAS. The field-expedient methods and equipment detailed in previous editions of this technical manual are no longer authorized.

c. With the exception of sealed, undamaged boxes, field-returned items must be individually inspected for serviceability, cleaned and repacked before reissue. Field-returned items will be given priority of issue.

d. Disposition instructions for items which fail surveillance inspection or test, are found in need of maintenance or exhibit some other anomaly will be requested of HQ, USA IOC, AMSIO-IOA-A, Rock Island, IL by means of an Ammunition Condition Report, AMC Form 1447.

3-2. Visual Inspection of Incoming Ammunition

a. Visually inspect for incoming ammunition packaging per paragraph 3-1a. above specifically for:

- (1) Penetrating type damage to a box which could have damaged the contents.
- (2) Crushing or gashing type damage to a box which could have damaged the contents.
- (3) Severe weathering (or other environmental damage) which could have damaged the contents.
- (4) Any damage to a box or pallet which could affect its integrity or ability to protect its contents.

(5) Legibility of the markings on boxes (do not depalletize ammunition for this, just inspect the boxes visible on the surface of the palletized load).

NOTE

The item nomenclature, DODIC, DOT/UN markings and lot number must all be legible.

- b. Depalletize and set aside for corrective action all boxes with any of the damage listed in a(1) through (4) above or having illegible markings.
- c. In a facility/area authorized for handling unpacked ammunition, unpack the contents of damage boxes only as far as necessary to determine if the ammunition itself has been damaged.
 - (1) Forward repairable damaged boxes to the car enter shop for repair or obtain replacement boxes from the local "box yard" from previously expended, similar ammunition.
 - (2) If it was necessary to unpack the ammunition completely, it must be visually inspected using the guidelines of TM 9-1375-213-12&P and common sense criteria.
 - (3) Good ammunition may be repacked and marked for priority of issue (since it has been unsealed and a vacuum pump and barrier bag sealer is not generally available at DS/GS
The organizational level repack procedures of TM 9-1375-213-12&P apply All boxes must be properly marked to show the contents, DOT/UN markings, and lot number.
 - (4) As permitted by local regulations and policy, ammunition considered unserviceable may be destroyed locally (small, inexpensive items) or reported to AMSIO-IOA-A, IOC through ammunition supply channels (larger, expensive items such as the M180 Demolition Kit).

THIS PAGE INTENTIONALLY LEFT BLANK

CHAPTER 4

MAINTENANCE PROCEDURES

4-1. General

Operations are not restricted to those in this manual and depend on the degree and/or type of maintenance being performed. Levels of maintenance to be performed are prescribed in the Maintenance Allocation Chart (MAC) in TM 9-1375-213-12.

4-2. Direct Support Maintenance

a. Direct support maintenance will be performed on demolition items as authorized by the MAC under the following conditions:

(1) Whenever care and preservation is required to ensure serviceability over a longer period.

(2) When requested by operator and/or organizational units to inspect suspected unserviceable ammunition. In addition to inspection, to test items and perform maintenance to return items to serviceable condition.

(3) Perform maintenance to correct deficiencies in suspended ammunition lots.

(4) To inspect ammunition upon receipt from ammunition supply points.

b. Maintenance operations include but are not limited to:

(1) Cleaning and protection of individual items and packing material.

(2) Removal of light rust.

(3) Repair of boxes, containers, and crates.

(4) Spot and complete painting and restenciling.

c. Ammunition companies are responsible for:

(1) Providing technical assistance to using units.

(2) Stocking authorized replacement components, packing materials, and expendable supplies. For components and supplies not authorized for storage, requisitions will be submitted to an inventory control point (ICP).

(3) Receiving packaging material (of expended ammunition), returned from organizational units, which are required for ammunition maintenance.

d. TM 9-1300-250 contains instructions for line layout and preparation of an SOP Prior to starting any maintenance operation, an SOP and a maintenance line layout must be prepared. Refer to TM 9-1300-250 for instructions.

e. Expendable and durable materials used by direct support and general support maintenance personnel are listed in Appendix C.

4-3. General Support Maintenance

a. General support maintenance will be performed on demolition items, as authorized by the MAC, under the same conditions as direct support. However, they will perform maintenance on larger stocks of ammunition outside the capability or authorization of direct support units.

b. Demilitarization of unserviceable ammunition may be performed by these units in accordance with TM 9-1300-206.

c. These units will stock replacement components, packaging materials, and expendable supplies to support lower level maintenance units.

d. Prior to starting any maintenance operations, an SOP and a maintenance line layout must be prepared. Refer to TM 9-1300-250 for instructions.

4-4. Rust Removal and Touchup

a. Receive items requiring rust removal and/or touchup from unpacking or inspecting operation.

b. Using cloth dampened with solvent, remove minor rust and defective markings as well as possible.

c. Use abrasive material or nonferrous wire brush to remove remaining rust from item.

d. Using paint brush and required enamel, touchup surfaces of demolition item where original coating has been damaged or removed. See table 4-2 for paint colors.

Table 4-1. Marking Information for Demolition Items

Item	Outer covering or body material and color	Color of markings	Height of letters	Marking
Demolition Charge Assembly M37.	Canvas, olive drab.	Black	1/2	(on haversack) CHARGE ASSEMBLY DEMOLITION, M37 (LOT NO.) (DATE LOADED).
Demolition Charge Assembly M183.	Canvas, olive drab.	Black	1/2	(on haversack) CHARGE ASSEMBLY DEMOLITION, M37 (LOT NO.) (DATE LOADED).
Shaped Charge: MK74 MOD 1.	Plastic, olive drab.	Black on yellow stripe.	1/4	US. NAVY CHARGE, DEMOLITION, SHAPED: MK74 MOD 1, NSN, DODIC, LOT NO., DATE OF MANUFACTURE.
15-LB Shaped Charge (HE).	Fiber, olive drab	Yellow	3/8	CHARGE, DEMO: SHAPED 15 LB M2A3 (or M2A4) PENTOLITE or COMP B (LOT NO.) (DATE LOADED).
15-LB Shaped Charge (Practice).	Fiber, light blue (No. 35109).	White	3.8	CHARGE, DEMO: SHAPED 15 LB M2A3 PRACTICE (LOT NO.) (DATE LOADED).
40-LB Shaped Charge.	Steel, olive drab.	Yellow	1 1/2	CHARGE, DEMO: SHAPED 40 LB M3A1 COMP B (LOT NO.) (DATE LOADED).
40-LB Cratering Charge. (older version)	Steel, olive drab	Yellow	1/2 1/4	CHARGE CRATERING 43 LB.
40-LB Cratering Charge. (New, 1992 version)	Steel, olive drab	Yellow	3/4 1/4	1-CHARGE, DEMOLITION 40 LB CRATERING, CHARGES DEMOLITION UN 0048. CAUTION EXPLOSIVE ITEM (LOT NO.) (DATE LOADED) FOR CRATERING WORK ONLY NOT TO BE USED FOR GENERAL BLASTING. DO NOT USE UNDERGROUND OR IN ENCLOSED SPACES.
Explosive Destructor M10 (universal).	Steel, olive drab or natural (do not repaint).	Yellow	1/8	M 10 HE DESTRUCTOR (LOT NO.) (DATE LOADED).
Explosive Destructor M19.	Aluminum alloy, green (No. 34807).	Yellow	1/4	(on body) DESTRUCTOR EXPLOSIVE M19 (LOT NO.) (DATE LOADED).
Demolition Charge Roll M186.	Canvas, olive drab.	Yellow	1/2 min.	(on haversack) 1-CHARGE DEMOLITION ROLL M186 15-HOLDER BLASTING CAP M8.
	Plastic, olive drab.	Yellow	1/2	(on reel) CHARGE DEMOLITION: ROLL M186 (LOT NO.) (DATE LOADED).
15-Second Delay Detonator M1A2.	Zinc alloy or aluminum alloy olive drab (do not repaint).	Yellow	1/8	DANGER 15-SECOND DELAY DETONATOR M1A2 (LOT NO.) (DATE LOADED).
&Second Delay Detonator M2A1.	Zinc alloy or aluminum alloy olive drab (do not repaint).	Yellow	1/8	DANGER 8-SECOND DELAY DETONATOR M2A1 (LOT NO.) (DATE LOADED).

Table 4-1. Marking Information for Demolition Items - Continued

Item	Outer covering or body material and color	Color of markings	Height of letters	Marking
Delay-Type(s) Demolition Firing Device M1	Copper, zinc alloy, olive drab.	None except safety strip.	None	
Pressure-Type Firing Device M1, M1A1.	Zinc alloy, green, black (inert)	Yellow white (inert).	1/8	FIRING DEVICE, PRESS TYPE M1A1 INERT (if inert) (LOT NO.) (DATE LOADED).
Pull-Type Demolition Firing Device M1.	Zinc alloy, olive drab (do not repaint).	Yellow	1/8	FIRING DEVICE DEMO PULL
Release-Type Demolition Firing Device M1	Steel, galvanized or cadmium plated.	None	None	
PULL-RELEASE-TYPE DEMOLITION FIRING Device M3.	Zinc alloy, olive drab (do not repaint).	Yellow	3/16	FIRING DEVICE PULL RELEASE TYPE, M3.
Pressure-Release-Type Demolition Firing Device M5.	Steel, olive drab (do not repaint).	Yellow	1/8	(on top) FIRING DEVICE PRESSURE RELEASE TYPE M5 (on side) (LOT NO.) (DATE LOADED).
Multipurpose Demolition Firing Device M142	Steel container, olive drab Body Material olive drab Plastic, (Do not paint) No Markings.	Yellow	1/4	FIRING DEVICE DEMO MULTIPURPOSE M142 (LOT NO.) (DATE) (on metal container).
Inert Firing Device M5	Steel, light blue (old ones are black).	White	1/8	FIRING DEVICE PRESSURE RELEASE TYPE M5 INERT
Time Blasting Fuse Igniter M2.	Zinc alloy, olive drab (do not repaint).	Yellow	1/8	IGNITER, BLASTING FUSE WEATHERPROOF M2 (INERT) (LOT NO.) (DATE LOADED).
Practice Shaped Charge M3.	Blue painted steel.	White	1	CHARGE, DEMO SHAPED 40 LB M3 PRACTICE (LOT NO.) (DATE MANUFACTURED).

e. Following touchup, place demolition item in safe location in work area until paint has dried, then transfer to next operation.

f. After removing rust or defective markings, transfer item requiring complete repainting to repainting operations.

g. Materials, tools, and equipment include the following:

- (1) Enamel.
- (2) Solvent,
- (3) Rags.
- (4) Paint brush.
- (5) Work table.

(6) Plunger-type safety can.

(7) Disposable gloves.

(8) Nonsparking wire brush.

(9) Flammable waste can.

4-5. Repainting
(Table 4-1)

CAUTION

DISPOSE OF RAGS CONTAMINATED WITH PAINTS AND SOLVENTS BY SUBMERGING IN WATER IN APPROVED WASTE CAN TO AWAIT BURNING.

a. Materials, tools, and equipment include the following:

- (1) Enamel.
- (2) Solvent.
- (3) Rags.
- (4) Paint spray outfit or paint brush.
- (5) Flammable liquid safety can.
- (6) Disposable gloves.
- (7) Masking tape.
- (8) Respirator.

b. Receive demolition items from rust removal operation.

c. Mask areas not to be painted.

d. Place item in painting area.

WARNING

WEAR PAINT SPRAY RESPIRATOR.

NOTE

Use an upper support to hold bangalore torpedoes in position.

e. Position item securely, exposing maximum area to be painted. Apply paint with brush, aerosol spray can, or safety-approved paint sprayer. Do not disturb wet paint when repositioning item for painting remaining area. Go on to next item to allow paint to dry before completing painting.

f. Inspect item for complete paint coverage. Touch-up and allow to dry thoroughly.

g. Remove masking tape. Transfer item to next operation.

4-6. Re-marking

a. *General.*

(1) When re-marking ammunition, the nomenclature, DODIC, and lot number must be accurately maintained.

(2) The above information must also be accurately reflected on re-marked ammunition boxes and containers. In addition, the DOT/UN shipping information must be accurately stenciled on the boxes. The old DOT shipping classes and markings have been replaced by the UN serial number (code) and proper shipping name. For ammunition boxes shipped within CONUS, the DOT markings may be used without updating until the year 2001, but the UN markings must be on all boxes shipped OCONUS. Because of these requirements, it is advisable that all ammunition boxes and containers being re-marked have the UN markings added. The UN markings may be placed over old markings that have been obliterated (using the sand paint listed in 4-7a.) or in a vacant area near the old DOT markings. The new and the old markings are given in Table 4-2 for all standard issue demolition items. The full requirements for marking ammunition boxes are given in figure 4-1. Container markings are similar and the old container markings can be used as a guide for placement, etc. Full re-markings may not be required on all items. Such items may have markings "touched-up" per procedures of TM 9-1375-213-12&P if this is acceptable to the local Quality Assurance Ammunition Surveillance (QASAS).

b. *Preparation.*

Stenciling over old markings is quite difficult because it requires a stencil of identical size, letter type and spacing as used on the original item unless the old markings are completely worn off. Painted demolition items (and containers) do not have critical outside diameter measurements like artillery projectiles so adding a fresh coat of olive drab enamel to cover old, damaged markings will present no problems (see repainting instructions, para 4-5). Boxes can be given a coat of the sand, marking obliterating lacquer over the old markings prior to remarking to give a clear surface.

c. *Equipment.*

(1) Material, tools, and equipment include the following:

(a) Marking stencil ink

(b) Solvent.

(c) Rags

(d) Rubber marking outfit or pre-cut stencil and stencil brush or stencil cutters, stencil board, and stencil brush.

(e) Work table.

- vent). (f) Plunger-type safety can (for solvent).
- (g) Disposable gloves.

NOTE

- For specific markings, see tables 4-1 and 4-2. For location of markings refer to figure 4-1 and table 4-3.
- Paint in the appropriate color may be substituted for ink, if necessary.
- Clean all marking equipment as often as necessary and at the end of each shift or termination of the job, whichever comes first.
- Re-marking is not required on plastic or waxed-paper surfaces; however, inner pack must be marked with the information usually found on item. If items have no inner packs, the information must be stenciled on cardboard and included in repacked box.

d. *Re-marking Methods.*

(1) Rubber-type method.

- (a) Apply a small dab of ink to ink plate.

- (b) Roll brayer back and forth on ink plate to distribute ink on brayer.
- (c) Roll inked brayer lightly across face of rubber type to apply light film of ink to type.
- (d) Place item in position to receive marking, then roll carefully across face of rubber type to apply ink marking.

(2) *Stencil method.*

- (a) Apply small dab of ink to ink plate.
- (b) Rub brush in ink to apply ink to bristles.
- (c) Position stencil over location on demolition item to receive marking. Secure with marking tape if necessary
- (d) While holding stencil firmly against item, rub bristles of brush over stencil to apply inked marking to demolition item.
- (e) *Remove stencil.*

(3) Check markings. Make sure they are correct, neat, and legible.

(4) Allow ink to dry before extensively handling or repacking item

Table 4-2. Box Marking Data

Quantity and item	Packing container	DODIC	DOT marking (old)	DOT/UN marking (new) (Proper Shipping Name)	UNO code (Serial No.)	No. items in box	No. items per inner pack	Total weight (lb)	Total explosive weight (lb)	Cube (ft)	QDC/SCG	Remarks
16 CHARGE, DEMOLITION: Block, M2.	Wood box	M036	HIGH EXPLOSIVES DANGEROUS	CHARGES, DEMOLITION	0048	16	8/haversack, 2/haversack/box.	57	40	1.3	1.1D	
16 CHARGE, DEMOLITION: Block, M3.	Wood box	M037	HIGH EXPLOSIVES DANGEROUS	CHARGES, DEMOLITION	0048	16	8/haversack, 2 haversack/box.	45	36	1.3	1.1D	
24 CHARGE, DEMOLITION: Block, M5A1.	Wood box	M038	HIGH EXPLOSIVES DANGEROUS	CHARGES, DEMOLITION	0048	24		80	60	1.6	1.1D	
30 CHARGE, DEMOLITION: Block, M112.	Wirebound box	M023	HIGH EXPLOSIVES DANGEROUS	CHARGES, DEMOLITION	0048	30		48	37.5	0.8	1.1D	
20 CHARGE, DEMOLITION: Block, M118.	Wirebound box	M024	HIGH EXPLOSIVES DANGEROUS	CHARGES, DEMOLITION	0048	20 sheets*		52	40	1.2	1.1D	
3 CHARGE, DEMOLITION: Roll, M186.	Wirebound box	M060	HIGH EXPLOSIVES DANGEROUS	CHARGES, DEMOLITION	0048	3		115	75	3.8	1.1D	
200 CHARGE, DEMOLITION: Block, TNT, 1/4-pound.	Wood box	M030	HIGH EXPLOSIVES DANGEROUS	CHARGES, DEMOLITION	0048	200		79	50	1.7	1.1D	
96 CHARGE, DEMOLITION: Block, TNT, 1/2-pound.	Wood box	M031	HIGH EXPLOSIVES DANGEROUS	CHARGES, DEMOLITION	0048	96		65	48	1.4	1.1D	
48 CHARGE, DEMOLITION: Block, TNT, 1-pound.	Wood box	M032	HIGH EXPLOSIVES DANGEROUS	CHARGES, DEMOLITION	0048	48		80	48	1.4	1.1D	
1 CHARGE, DEMOLITION: Cratering, 40-pound.	Wood box	M039	HIGH EXPLOSIVES DANGEROUS	CHARGES, DEMOLITION	0048	1	1	52	40	1.2	1.1D	
1 CHARGE, DEMOLITION: Cratering, 40-pound (New)	Metal propelling charge container	M039	HIGH EXPLOSIVES DANGEROUS	CHARGES, DEMOLITION	0048	1	1	58.9	40.5	1.3	1.1D	

Table 4-2. Box Marking Data - Continued

Quantity and item	Packing container	DODIC	DOT marking (old)	DOT/UN marking (new) (Proper Shipping Name)	UNO code (Serial No.)	No. items in box	No. items per inner pack	Total weight (lb)	Total explosive weight (lb)	Cube (ft)	QDC/SCG	Remarks
3 CHARGE, DEMOLITION: Shaped, M2A3 and M2A4.	Wood box	M420	HIGH EXPLOSIVES DANGEROUS	CHARGES, DEMOLITION	0048	3	1/ctn, 3 ctn/box	65	34.5	1.3	1.1D	
1 CHARGE, DEMOLITION: Shaped, M3.	Wood box	M421	HIGH EXPLOSIVES DANGEROUS	CHARGES, DEMOLITION	0048	1		65	30	1.8	1.1D	
1 CHARGE, DEMOLITION: Shaped, M3A1.	Wood box	M421	HIGH EXPLOSIVES DANGEROUS	CHARGES, DEMOLITION	0048	1		65	30	1.8	1.1D	
6 CHARGE, DEMOLITION: SHAPED: MK74 MOD 1.	Wirebound box	M832	HIGH EXPLOSIVES DANGEROUS	CHARGES, DEMOLITION	0048	2	2/M2A1 Cont. Plus 2 MK74 Inert chg.	25.2	0.616	0.85	1.1D	
2 CHARGE ASSEMBLY, DEMOLITION: M183.	Wood box	M757	HIGH EXPLOSIVES DANGEROUS	CHARGES, DEMOLITION	0048	2 Chg assy*	16 charges/canvas bag. 2 bag/box.	57	40	1.5	1.1D	Each charge assy contains 16 M112 charges.
2 CHARGE ASSEMBLY, DEMOLITION: M37.	Wood box	M756	HIGH EXPLOSIVES DANGEROUS	CHARGES, DEMOLITION	0048	2 Chg assy*	8 charges/canvas bag. 2 bag/box.	57	40	1.5	1.1D	Each charge assy contains 8 M5A1 charges.
1 DEMOLITION KIT, BANGALORE TORPEDO: M1A1.	Wood box	M026	EXPLOSIVE BOMB	BOMBS, W/BURSTING CHARGE	0034	1		176	90	4.1	1.1D	
1 DEMOLITION KIT, BANGALORE TORPEDO: M1A2.	Wood box	M028	EXPLOSIVE BOMB	BOMBS W/ BURSTING CHARGE	0034	1		198	115	4.1	1.1D	
100 DYNAMITE MILITARY, M1.	Wood box	M591	HIGH EXPLOSIVES DANGEROUS	EXPLOSIVE, BLASTING, TYPE B	0082	100	2/packages 50 each.	80	43	1.6	1.1D	
4,000 ft FUSE, BLASTING, TIME: (safety fuse).	Wood box	M670	SAFETY FUSE	FUZES, SAFETY	0105	80 coil*	2 coil/package 5 pkg/mtl can 8 can box.	93.5	.35	3.7	1.4S	50-ft coil.

Table 4-2. Box Marking Data - Continued

Quantity and item	Packing container	DODIC	DOT marking (old)	DOT/UN marking (new) (Proper Shipping Name)	UNO code (Serial No.)	No. items in box	No. items per inner pack	Total weight (lb)	Total explosive weight (lb)	Cube (ft)	QDC/SCG	Remarks
4,000 ft FUSE, BLASTING, TIME: M700.	Wood box	M670	SAFETY FUSE	FUZES, SAFETY	0105	80 coil*	2 coil/package 5 pkg/mtl can 8 can box.	64.5	.35		1.4S	50-ft coil.
500 CAP, BLASTING: Electric, J-2, type II.	Wood box	M130	DETONATORS - HANDLE CAREFULLY	DETONATORS, ELECTRIC, for blasting	0030	500	C*		1.45		1.1B	C = Commercial
900 CAP, BLASTING: Electric, M6.	Wood box	M130	DETONATORS - HANDLE CAREFULLY	DETONATORS, ELECTRIC, for blasting	0030	900	6/ctn, 1 ctn/wtprf bag, 25 bag/fbrbd cnt, 6 cntr/box.	114	2.62		1.1B	
5,000 CAP BLASTING: Nonelectric, J-1.	Wood box	M131	DETONATORS - HANDLE CAREFULLY	DETONATORS, NON-ELECTRIC, for blasting	0029	5,000	50/can, 20 can/fbrbd cnt, 5 cntr/box.		13.75	2.3	1.1B	
3,600 CAP BLASTING: Nonelectric, M7.	Wood box	M131	DETONATORS - HANDLE CAREFULLY	DETONATORS, NON-ELECTRIC, for blasting	0029	3,600	6/ctn, 1 ctn/barrier bag, 50 bag/cntr, 12 cntr/box.		9.92	3	1.1B	
10 CAP, BLASTING: Electric, M6	Wood box (Non-propagating pack)	M130	DETONATORS - HANDLE CAREFULLY	DETONATORS, ELECTRIC, for blasting	0255	10	1 plastic tube, 10 tubes/box		.028		1.4B	
10 CAP, BLASTING: Nonelectric, M7	Wood box (Non-propagating pack)	M131	DETONATORS - HANDLE CAREFULLY	DETONATORS, NON-ELECTRIC, for blasting	0267	10	1 plastic tube, 10 tubes/box		.028		1.4B	
200 DETONATOR, PERCUSSION: 15-second delay, M1A2.	Wood box	M450	TIME FUSES HANDLE CAREFULLY	FUZES, DETONATING	0257	200	10/ctn, 1 ctn/barrier bag, 5 bag/cntr, 12 cntr/box.	75	1.8	2.3	1.1B	
200 DETONATOR, PERCUSSION: 8-second delay, M2A1.	Wood box	M448	TIME FUSES HANDLE CAREFULLY	FUZES, DETONATING	0257	200	10/barrier bag, 5 bag/ctn, 5 ctn/box.	62	1.6	4.1	1.1B	
50 DETONATOR KIT, CONCUSSION: M1.	Wood box	M540	DETONATING FUSES CLASS C EXPLOSIVES HANDLE CAREFULLY	FUZES, DETONATING	0107	50	1/metal cnt, 50 cnt/box.	59	0.2	2.4	1.2B	

Table 4-2. Box Marking Data - Continued

Quantity and item	Packing container	DODIC	DOT marking (old)	DOT/UN marking (new) (Proper Shipping No.)	UNO code (Serial No.)	No. items in box	No. items per inner pack	Total weight (lb)	Total explosive weight (lb)	Cube (ft)	QDC/SCG	Remarks
50 DESTROYER, EXPLOSIVE: Universal, M10.	Wood box	M241	BOOSTERS (EXPLOSIVE) HANDLE CAREFULLY	BOOSTERS, WITHOUT DETONATOR	0042	50	1/fbr cntr, 50 cntr/box.	78	15.1	2.4	1.1D	
6 DESTROYER, EXPLOSIVE: Universal, M19.	Wood box	M235	EXPLOSIVE MINES	MINES, WITH BURSTING	0137	6	1/fbr cntr, 6 cntr/box.		2.73	0.8	1.1D	
2,500 IGNITER, TIME BLASTING FUSE: Friction, M1.	Wood box	M765	IGNITERS HANDLE CAREFULLY	LIGHTERS, FUSE		2,500	10 ctn, 250 ctn/box.	62.5		3.37	1.4S	
150 IGNITER, TIME BLASTING FUSE; Weatherproof, M2.	Wood box	M766	FUSE LIGHTER HANDLE CAREFULLY	LIGHTERS, FUSE	0131	150	5/ctn, 30 ctn/box.	29	0.02		1.4S	
300 IGNITER, TIME BLASTING FUSE; Weatherproof, M60.	Wood box	M766	FUSE IGNITERS HANDLE CAREFULLY	LIGHTERS, FUSE	0131	300	5/ctn, 60 ctn/box.	56	0.02	2	1.4S	
4,000 ft CORD, DETONATING	Wood box	M456	CORDEAU DETONANT FUSE - HANDLE CAREFULLY	CORD, DETONATING, FLEXIBLE	0065	4,000 ft	500 ft/can, 8 can/wdn box.	117	29	4	1.1D	
450 FIRING DEVICE, DEMOLITION: Delay, M1.	Wirebound box	M616	FIRING DEVICES HANDLE CAREFULLY	ARTICLES, EXPLOSIVE, N.O.S.	0349	450	10/ctn, 1 ctn/bag, 15 bag/fbrbd cntr, 3 cntr/box.	56	0.03	1.2	1.4S	
450 FIRING DEVICE, DEMOLITION: Delay, M1.	Wirebound box	M619	FIRING DEVICES HANDLE CAREFULLY	ARTICLES, EXPLOSIVE, N.O.S.	0349	450	10/ctn, 1 ctn/bag, 15 bag/fbrbd cntr, 3 cntr/box.	56	0.03	1.2	1.4S	
450 FIRING DEVICE, DEMOLITION: Delay, M1.	Wirebound box	M620	FIRING DEVICES HANDLE CAREFULLY	ARTICLES, EXPLOSIVE, N.O.S.	0349	450	10/ctn, 1 ctn/bag, 15 bag/fbrbd cntr, 3 cntr/box.	56	0.03	1.2	1.4S	
450 FIRING DEVICE, DEMOLITION: Delay, M1.	Wirebound box	M621	FIRING DEVICES HANDLE CAREFULLY	ARTICLES, EXPLOSIVE, N.O.S.	0349	450	10/ctn, 1 ctn/bag, 15 bag/fbrbd cntr, 3 cntr/box.	56	0.03	1.2	1.4S	
450 FIRING DEVICE, DEMOLITION: Delay, M1.	Wirebound box	M622	FIRING DEVICES HANDLE CAREFULLY	ARTICLES, EXPLOSIVE, N.O.S.	0349	450	10/ctn, 1 ctn/bag, 15 bag/fbrbd cntr, 3 cntr/box.	56	0.03	1.2	1.4S	

Table 4-2. Box Marking Data - Continued

Quantity and item	Packing container	DODIC	DOT marking (old)	DOT/UN marking (new) (Proper Shipping Name)	UNO code (Serial No.)	No. items in box	No. items per inner pack	Total weight (lb)	Total explosive weight (lb)	Cube (ft)	QDC/SCG	Remarks
450 FIRING DEVICE, DEMOLITION: Delay, M1.	Wirebound box	M623	FIRING DEVICES HANDLE CAREFULLY	ARTICLES, EXPLOSIVE, N.O.S.	0349	450	10/ctn, 1 ctn/bag, 15 bag/fbrbd cntr, 3 cntr/box.	56	0.03	1.2	1.4S	
250 FIRING DEVICE, DEMOLITION: Pressure release, M1 and M1A1	Wood box	M626	PERCUSSION FUSE HANDLE CAREFULLY	ARTICLES, EXPLOSIVE, N.O.S.	0349	250	5/box, 50 box/wdn box.	80	0.014	2.1	1.4S	
200 FIRING DEVICE, DEMOLITION: Pressure-release, M5.	Wood box	M627	PERCUSSION FUSE HANDLE CAREFULLY	ARTICLES, EXPLOSIVE, N.O.S.	0349	200	4/box, 5 box/fbrbd box, 10 fbrbd box/wdn box.	46.2	0.011	1.6	1.4S	
200 FIRING DEVICE, DEMOLITION: Pull, M1.	Wood box	M630	PERCUSSION FUSE HANDLE CAREFULLY	ARTICLES, EXPLOSIVE, N.O.S.	0349	200	5/box, 1 box/foil envelope, 40 env/box.	59	0.011	1.9	1.4S	
150 FIRING DEVICE, DEMOLITION: Pull-release, M3.	Wood box	M629	PERCUSSION FUSE HANDLE CAREFULLY	ARTICLES, EXPLOSIVE, N.O.S.	0349	150	5/pkg, 30 pkg/box.	35	0.029	0.7	1.4S	
80 FIRING DEVICE DEMOLITION: Release, M1.	Wood box	M631	PERCUSSION FUSE HANDLE CAREFULLY	ARTICLES, EXPLOSIVE, N.O.S.	0349	80	4/box, 20 box/wdn box.	44	0.011	1.4	1.4S	
500 COUPLING BASE, FIRING DEVICE.	Wood box	M327	SMALL ARMS PRIMERS-HANDLE CAREFULLY	PRIMERS, CAP TYPE	0044	500	50/ctn, 10 ctn/box.	35	0.09	1.3	1.4S	
FIRING DEVICE, DEMOLITION: Multipurpose, M142.	Wood box	ML03	SMALL ARMS PRIMERS-HANDLE CAREFULLY	PRIMERS, CAP TYPE	0044	56	14/box, 4 box/cntr	43	0.035	92	1.4S	
5,000 PRIMER, PERCUSSION: Cap, M2 and improved No. 3.	Wood box	M810	SMALL ARMS PRIMERS-HANDLE CAREFULLY	PRIMERS, CAP TYPE	0044	5,000	100/ctn, 50 ctn/box.	24	0.29	0.9	1.4S	

* See remarks column.

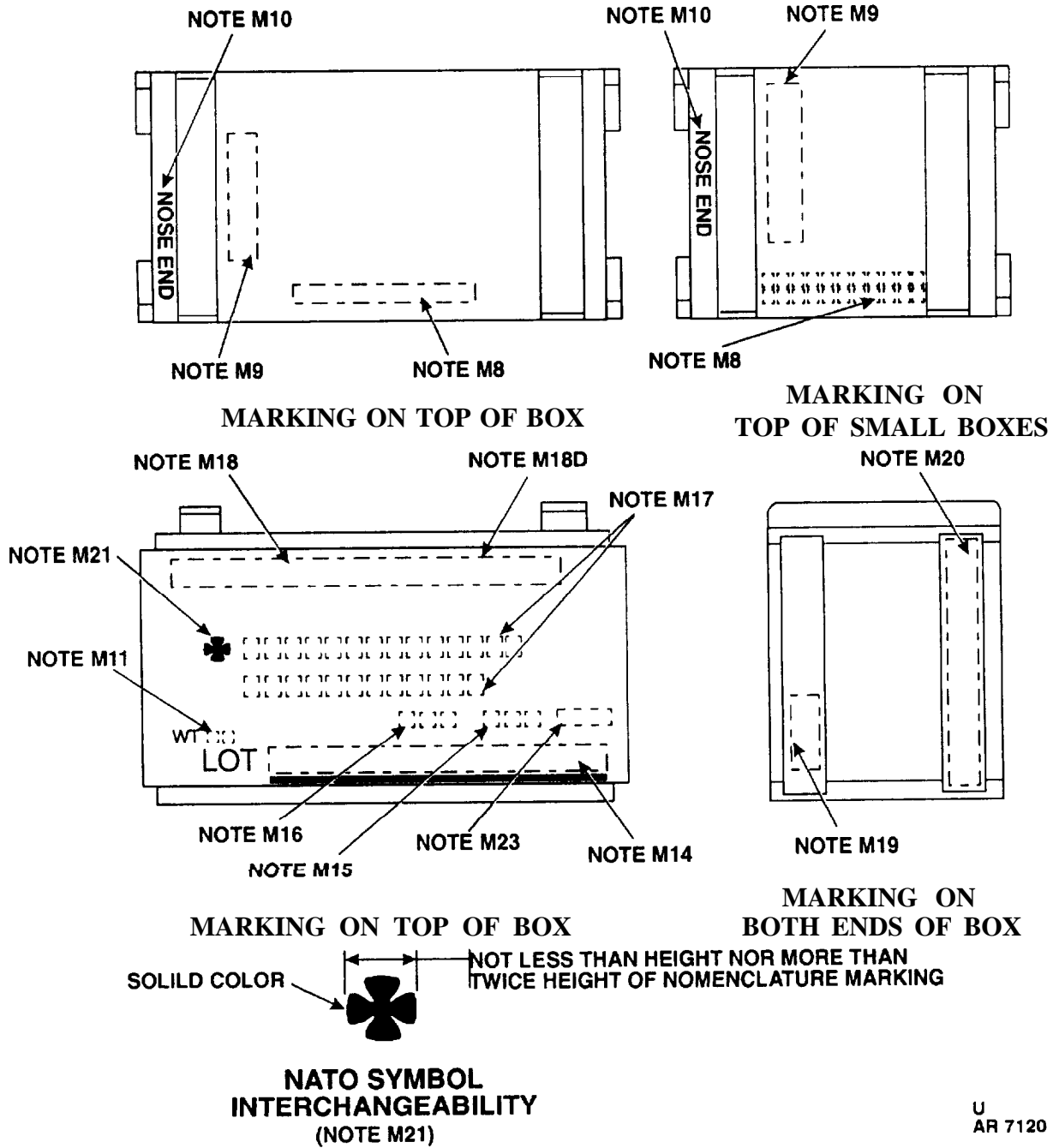

Figure 4-1. Woodbox - location of markings.

Table 4-3. Location of Markings

PACKAGING COMPONENTS

SEAL, METALLIC-8794342-1, -2, -3, -4, -5, OR 6

PACKING FOR LIGHT BOXES 9325874

NOTES:

- 1-SPEC MIL-A-002550 APPLIES
- 2-MATERIAL: INK, STENCIL, BLACK NO. 37038, TYPE II, III, OR IV SPEC A-A-208.
 - A-ALTERNATIVE: INK IN ACCORDANCE WITH DWG 9211789
 - B-ALTERNATIVE: LACQUER (ENAMEL) NITROCELLULOSE AND ACRYLIC, AEROSOL SPEC TT-L-50
 - C-ALTERNATIVE: PAINT, STENCIL, FLAT, SPEC A-A-1558
 - D-ALTERNATIVE: MARK IN ACCORDANCE WITH DWG 9295098 WIDTH OF LETTER STROKE SHALL BE APPROXIMATELY EQUAL TO THAT OBTAINED WITH STENCIL.
- 3-MATERIAL: PAINT, ORANGE NO. 32246, SPEC TT-P-96
 - A-ALTERNATIVE: PAINT, STENCIL, FLAT, SPEC A-A-1558
 - B-ALTERNATIVE: LACQUER (ENAMEL) NITROCELLULOSE AND ACRYLIC. AEROSOL. ORANGE NO. 12197 OR NO. 12215, SPEC TT-L-50

MARKING INSTRUCTIONS

- M1- THE MARKING OF WOOD SHIPPING BOXES FOR AMMUNITION ITEMS SHALL BE PLACED ON TOP ONE SIDE AND BOTH ENDS. (BOTH ENDS TO BE MARKED ALIKE) IN ACCORDANCE WITH TYPICAL MARKING DIAGRAMS, NOTES AND MARKING INSTRUCTIONS CONTAINED ON THIS DRAWING AND APPLICABLE PACKING AND MARKING BOX DRAWING.
- M2- LETTERS AND FIGURES SHALL BE MARKED WITH BLACK STENCIL INK. (NOTE 2)
- M3- THE DESIRED HEIGHT OF LETTERS AND FIGURES AND MINIMUM SIZE ALLOWED ARE AS FOLLOWS:

<u>MARKING</u>	<u>DESIRED SIZE</u>	<u>MINIMUM SIZE</u>
A- NATIONAL STOCK NUMBER AND D.O.D. IDENTIFICATION CODE (DODIC) -----	1.INCH HIGH	7/16 INCH HIGH
B- LOT NUMBER -----	1.INCH HIGH	1. INCH HIGH
THE LETTERS AND FIGURES OF THE LOT NUMBER MAY BE 7/16 INCH MIN HEIGHT ON CLEATS OF SHALLOW DEPTH BOXES AND ON SIDE OF BOXES ONLY IN CASES WHERE ALLOWABLE SPACE IS INSUFFICIENT FOR 1 INCH CHARACTERS.		
C- DESCRIPTIVE NOMENCLATURE, CALIBER AND WEAPON DESIGNATION ----	1.INCH HIGH	7/16 INCH HIGH
D- ALL OTHER MARKING -----		7/16 INCH HIGH

- E- THE SIZES AND SPACES OF LETTER BLOCKS ARE REPRESENTATIVE OF STANDARD MACHINE CUT STENCIL LETTERING
- F- DEVIATIONS IN SIZE OF LETTERS AND FIGURES WITHIN LIMITS SPECIFIED ABOVE WILL BE PERMITTED WHEN SIZE OF BOX IS SUCH THAT THE DESIRED SIZE SPECIFIED IS NOT PRACTICAL.
- G- WHEN NECESSARY TO DEVIATE FROM DESIRED SIZE, THE LETTERS AND FIGURES SHALL BE APPROXIMATELY PROPORTIONAL TO THE SIZES LISTED.
- H- THE RELATIVE POSITIONS OF THE VARIOUS MARKING SHALL BE AS SHOWN. MARKING SHALL BE PLACED TO AVOID INTERFERENCE WITH WIRES OR HARDWARE.
- I- THE MARKING BLOCKS :.....: SHOWN ARE FOR ILLUSTRATION PURPOSES ONLY AND DO NOT NECESSARILY REPRESENT THE REQUIRED INFORMATION TO BE ENTERED.

Table 4-3. Location of Markings - Continued

- M4- WHEN HINGE AND HASP FITTINGS ARE USED, THE MARKING SHALL APPEAR ON THE SIDE TO WHICH THE HASP IS FASTENED.
- M5- WHEN FLAT BAND STRAPPING IS USED, LOCATE MARKING WITH CLEAR SPACE 1 INCH WIDE AT STRAPPING LOCATION.
- M6- THE WORDS "FLASHLESS" OR "SMOKELESS" WHEN REQUIRED IN THE DESCRIPTIVE NOMENCLATURE OF THE ITEM PACKED WILL BE SPELLED OUT COMPLETELY. THE WORDS "FLASHLESS-SMOKELESS" MAY BE ABBREVIATED WHEN NECESSARY, AS FOLLOWS - "FLHLS - SMKLS".
- M7- MARKING SHALL NOT BE EMBOSSED OR INDENTED BELOW THE SURFACE OF THE WOOD.
- MS- INSERT PROPER SHIPPING NAME AND IDENTIFICATION NUMBER AS REQUIRED BY PACKING AND MARKING BOX DRAWING. PROPER SHIPPING NAME AND IDENTIFICATION NUMBER ARE TO BE SEPARATED WITH A SPACE.
- A- MAY BE PLACED GIRTHWISE ON COVER.
- B- ALTERNATIVE: FOR SMALL BOX WITH 'TOP HANDLES: MAY BE PLACED ON SIDE OF BOX, SPACED 1/4 INCH MINIMUM FROM TOP EDGE WITH OTHER MARKING PRESCRIBED FOR SIDE OF BOX PLACED BELOW PROPER SHIPPING NAME/IDENTIFICATION NUMBER MARKING SPACED AS SHOWN.
- M9- APPLY THE STORAGE TEMPERATURE LIMIT INDICATED, WHEN PACKING ROCKET AMMUNITION (INCLUDING ROCKETS, ROCKET MOTORS AND JATO UNITS) CONTAINING NITROCELLULOSE PROPELLANT. STORAGE TEMPERATURE LIMITS SHALL BE ENCLOSED IN A SQUARE WITH THE WORDS "STORAGE TEMPERATURE LIMITS". THE TEMPERATURE SHALL BE INDICATED BY A FIGURE FOLLOWED BY THE LETTER "C" (CELSIUS) OR "F" (FAHRENHEIT) AS APPROPRIATE.
- M10- WHEN ROCKET AMMUNITION (INCLUDING ROCKETS, ROCKET MOTORS AND JATO UNITS) IS PACKED, END OR SIDE EDGE OF BOX TOP OVER NOSE OF ROCKET AMMUNITION MUST BE MARKED "NOSE END" WHEN WP SMOKE ARTILLERY AMMUNITION IS PACKED. COVER OF END OF BOX TOWARD WHICH FUZE IS POINTED MUST BE MARKED "NOSE END". MARKING MAY BE PLACED AT EITHER END OF BOX TO COINCIDE WITH AMMUNITION POSITION.
- M11- INSERT GROSS WEIGHT BY WEIGHING TWO REPRESENTATIVE SAMPLES AND AVERAGING THE WEIGHT.
- M12- MARKING OF BOX SHALL BE AS SPECIFIED IN MIL-STD-129-1 WHEN CARTRIDGES OF MORE THAN ONE LOT NUMBER ARE PACKED.
- M13-
- M14- INSERT LOT NUMBER. UNDERLINE ON SIDE OF BOX ONLY, WITH SOLID LINE 1/8 INCH WIDE MINIMUM.
- M15- INSERT ZONE MARKING, IF APPLICABLE. THE ZONE MARKING WILL BE MARKED ON THE BOX WHEN INDICATED ON THE PROJECTILE PACKED. SOLID SQUARES OF THE SAME COLOR AS THE OTHER LETTERING ON THE BOX SHALL BE USED TO INDICATE THE WEIGHT ZONE OF ALL AMMUNITION.
- M16- INSERT BURSTING CHARGE, IF APPLICABLE. THE BURSTING CHARGE WILL BE MARKED ON THE BOXES OF ALL HIGH EXPLOSIVE AMMUNITION.
- M17- INSERT APPROPRIATE QUANTITY, DESCRIPTIVE NOMENCLATURE, CALIBER AND WEAPON DESIGNATION AS SHOWN ON APPLICABLE PACKING AND MARKING BOX DRAWING.
- M18- INSERT NATIONAL STOCK NUMBER AND D.O.D. IDENTIFICATION CODE (DODIC) TO BE LOCATED AS FOLLOWS:
- A- IN LINE WITH THE HASP ON SHALLOW DEPTH BOXES.
- B- WILL READ ON ONE CONTINUOUS LINE BUT MAY BE PLACED BELOW HARDWARE ON SMALL BOXES OF INSUFFICIENT LENGTH.
- C- TO BE PLACED ON THE TOP LINE OF THE MARKING ON THE SIDE OF THE BOX.
- D- THE (DODIC) WILL BE SET APART FROM NSN BY A DASH.
- M19- INSERT D.O.D. IDENTIFICATION CODE (DODIC) IF APPLICABLE. (DODIC) STARTS AT BOTTOM OF CLEAT OR END BATTEN (WIREBOUND BOXES).

Table 4-3. Location of Markings - Continued

- M20- INSERT LOT NUMBER. THE WORD "LOT" SHALL NOT BE USED. LOT NUMBERS SHALL BE ON ONE OR TWO LINES STARTING AT BOTTOM OF END CLEAT OR END BATTEN (WIREBOUND BOXES). WHEN TWO LINES ARE USED, LOT NUMBER SHALL BE DIVIDED BETWEEN DATE DESIGNATION AND LOT INTERFIX NUMBERS.
- M21- WHEN REQUIRED BY ITEM SPECIFICATION OR PACKING AND MARKING BOX DRAWING, SEE MIL-STD-397. APPLY NATO SYMBOL OF INTERCHANGEABILITY TO LEFT (AS SHOWN) OR RIGHT OF NOMENCLATURE ON SIDE OF BOX USING SAME INK AND COLOR AS REQUIRED FOR LETTERING.
- M22-
- M23- AREA RESERVED FOR BAR CODE LABELS. SEE INSTRUCTIONS SHEET.

CORRECTION OF MARKING AND RE-MARKING

WHEN MARKING IS TO BE CORRECTED OR REPLACED, THE OLD MARKING SHALL BE EITHER SANDED OFF OR OBLITERATED AS SPECIFIED IN MIL-STD-129-1 (REF) SO THAT NO "SHOW-THROUGH" IS VISIBLE. NEW MARKING SHALL BE APPLIED AS STATED HEREON. RE-MARKING THROUGHOUT A LOT SHALL BE UNIFORM, CLEAN AND CLEARLY LEGIBLE. RE-MARKING TO CORRECT POOR WORKMANSHIP SHALL BE KEPT TO A MINIMUM. REMARKING MAY BE ACCOMPLISHED THROUGH COMPLETE OBLITERATION OF A PANEL OR SPOT OBLITERATION AS DEEMED ACCEPTABLE BY THE RESPONSIBLE GOVERNMENT ACTIVITY.

MARKING INSTRUCTIONS FOR GROUP A CHEMICAL AMMUNITION

A BOX CONTAINING GROUP A CHEMICAL AMMUNITION SHALL BE MARKED IN ACCORDANCE WITH THIS DRAWING AND SHALL BE COLOR CODED IN ACCORDANCE WITH INSTRUCTIONS CONTAINED IN DRAWING D150-2-1 (REF), CODE IDENT NO. 81361, EDGEWOOD ARSENAL, MARYLAND.

MARKING INSTRUCTIONS FOR LESS THAN FULL BOXES

- MLF 1- WHEN LESS THAN FULL BOX (LIGHT BOX) OF ANY AMMUNITION ITEM IS PACKED IN A BOX LESS THAN THREE CUBIC FEET. THE BOX SHALL BE PAINTED ORANGE AND APPROPRIATELY MARKED (NOTES 3 AND MLF 4).
- MLF 2- THE WORDS "LIGHT BOX" SHALL BE MARKED ON THE TOP AND THE SIDE OF THE BOX THAT CONTAINS THE IDENTIFICATION MARKING, IF SPACE PERMITS. IF THERE IS NO SPACE, THE LIGHT BOX MARKINGS SHALL BE PLACED ON THE ADJACENT END PANEL. THE SIZE OF THE LETTERING IS THE SAME AS USED FOR NOMENCLATURE MARKINGS.
- MLF 3- FOR DEFINITION AND PACKING OF LIGHT BOX SEE DWG 9325874 (REF).
- MLF 4- A LIGHT BOX 3 CUBIC FEET OR LARGER SHALL BE IDENTIFIED BY MARKING THE WORDS "LIGHT BOX" IN ORANGE, NOTE 3, ON THE TOP BOTTOM, SIDES, AND ENDS OF THE BOX IN THE LARGEST PRACTICAL LETTERS. (SKIDDED CONTAINERS SHALL NOT BE MARKED ON THE BOTTOM.)

MARKING INSTRUCTIONS FOR INTERPLANT SHIPMENT

- MIS 1- WHEN THE ITEMS PACKED ARE INTENDED ONLY FOR INTERPLANT SHIPMENT THE INFORMATION REQUIRED ON THIS DRAWING EXCEPT FOR PROPER SHIPPING NAME AND IDENTIFICATION NO. AND POP MARKING, MAY BE PLACED ON LABELS.

Table 4-3. Location of Markings - Continued

- M1S 2-2 LABELS SHALL BE SECURELY ATTACHED TO EACH BOX, ONE EACH ON THE FRONT SIDE AND ONE ON THE END TO THE RIGHT OF THE FRONT: ALTERNATIVELY ONE LABEL SHALL BE PLACED ON TOP INSTEAD OF THE END IF END PLACEMENT IS NOT PRACTICAL.
- M1S 3- LETTER HEIGHT SPECIFIED IN MARKING INSTRUCTIONS DO NOT APPLY TO LABELS.
- M1S 4- LABELS SHALL BE ATTACHED BY ANY METHOD WHICH WILL PERMIT EASY REMOVAL: I.E. TACKS, STAPLES.
- M1S 5- PROPER SHIPPING NAME AND IDENTIFICATION NUMBER AND POP MARKING MUST BE APPLIED DIRECTLY TO THE BOX AS SHOWN.
- M1S 6- WHEN SPECIFIED ON PACKING AND MARKING DRAWING, THE WORDS, "FOR CONUS SHIPMENT ONLY" SHALL BE APPLIED TO THE BOX DIRECTLY BELOW THE POP MARKING.

MARKING INSTRUCTIONS FOR METAL PARTS SHIPMENT

- MMP 1- WHEN METAL PARTS ARE SHIPPED IN ISSUE ITEM BOXES, MARKING INFORMATION WILL BE APPLIED ON BOX LABELS.
- MMP 2- ATTACH 2 LABELS (NOTES M1S 2, M1S 3, M1S 4)
- MMP 3- LETTER HEIGHT WILL BE 1/4 INCH MINIMUM.
- MMP 4- THE FOLLOWING INFORMATION WILL BE SHOWN:
 PART NUMBER
 (QUANTITY) (NOMENCLATURE)
 LOT NO.
 CONTRACT NO.:
 WT: CU:

SEALING INSTRUCTIONS (NAILED WOOD)

- SN 1- METHOD OF SEALING HASP AND HINGE HARDWARE:
 A- CLOSE COVER, FASTEN HASP WITH SWIVELS AND PASS METALLIC SEAL WIRE THROUGH EYELETS OF HASPS AND SWIVELS.
 B- WITH WIRE PULLED TIGHT, SECURE METALLIC SEAL WITH SEALING TOOL IN ACCORDANCE WITH DWG 8794342 (REF)
- SN 2- METHOD OF SEALING WING NUTS FOR CLOSURE OF END OPENING BOXES:
 A- WITH LOOSE END OF BOX AND BOLT IN POSITION, APPLY WASHER AND THUMB NUT AND SECURE TIGHTLY.
 B- INSERT METALLIC SEAL WIRE THROUGH HOLE IN BOLT, LOOP TIGHTLY AROUND ONE WING OF THUMB NUT AND SECURE METALLIC SEAL WITH SEALING TOOL IN ACCORDANCE WITH DWG 8794342 (REF).
- SN 3- STRAPPING OF BOX:
 A- STRAPPING SHALL BE LOCATED IN ACCORDANCE WITH APPENDIX OF SPEC MIL-B-2427 (REF) ON THE GIRTH OF THE BOX.
 B- THE LOCATION OF THE CONNECTORS IS OPTIONAL.
 C- FULL TIGHT UNTIL STRAPPING CUTS INTO EDGE OF BOX. THEN SEAL WITH CONNECTOR.
 D- WHEN USING ALTERNATIVE STRAPPING, SEAL IN ACCORDANCE WITH MANUFACTURER'S INSTRUCTIONS.

SEALING INSTRUCTIONS (WIREBOUND)

- SW 1- METHOD OF SEALING BY CLOSING LOOPS:
 A- CLOSE LOOPS AS SHOWN IN FIGURE 9 OF SPEC MIL-B-46506 (REF).
- SW 2- METHOD OF SEALING WITH METALLIC SEAL:
 A- APPLY METALLIC SEAL UNDER CENTER WIRE AND THROUGH LOOP AS SHOWN IN FIGURE 1.

Table 4-3. Location of Markings - Continued

B- SECURE METALLIC SEAL WITH SEALING TOOL IN ACCORDANCE WITH DWG 8794342 (REF).

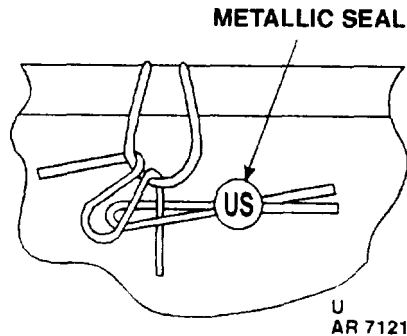

FIGURE 4-2. VIEW OF SEAL, METALLIC
REPAIR INSTRUCTION (WIREBOUND)

ALL BROKEN LOOPS SHALL BE REPAIRED AS SHOWN IN FIGURE 10A OF SPEC MIL-B-46506 (REF)

INSTRUCTIONS FOR RE-USE OF WOOD BOXES AND PACKAGING MATERIALS (INTERPLANT ONLY)

- IR 1- RE-USE OF PACKAGING MATERIALS (EXCEPT PACKAGING MADE OF PAPER, PLASTIC FILM, OR TEXTILES AND SPECIFICALLY BARRIER BAGS) IS PERMISSIBLE IF CONSIDERED ECONOMICALLY FEASIBLE AND IN USABLE CONDITION BY THE PROCURING ACTIVITY
- IR 2- WOOD BOXES SHALL BE REJECTED FOR RE-USE UPON DETECTION OF ANY OF THE FOLLOWING:
 - A- CONTAMINATION FROM EXPLOSIVE MATERIAL, OIL OR GREASE ON INTERIOR.
 - B- NAILS MISSING, LOOSE OR MISSING KNOTS.

NOTE

The DOT/UN shipping classification for old-packaged electric and nonelectric blasting caps was changed in the early 1990's. The classification was changed from the old DOT "EXPLOSIVE C-BLASTING CAPS" to the old "EXPLOSIVE A - DETONATORS - HANDLE CAREFULLY". These designations were, in turn, replaced by the new UN Proper Shipping Names and Codes given in table 4-3. This does not apply to the new, non-propagating packages which should have been marked with different UN markings at the factory. Use the proper markings for the packaging given in table 4-3.

4-7. Inspecting and Reconditioning Packing Box

a. Materials, tools, and equipment include the following:

- (1) Work table.
- (2) Roller conveyor,
- (3) Wood scraper.
- (4) Rags.
- (5) Claw hammer.
- (6) Hand nail puller.
- (7) Stencil (to be made on site).
- (8) Screwdriver.
- (9) Paint brush.
- (10) Marking ink.
- (11) Enamel.
- (12) Lacquer, sand, marking obliterating.
- (13) Solvent.
- (14) Nails (assorted sizes).

- b. Receive packing box from unpacking operation
- c. Examine box and repair, recondition, and accept or reject as prescribed in TM 9-1375-213-12.

- d. Transfer accepted packing box to packing operation. If rejected, mark and place in reject area pending disposal.

4-8. Inspecting Barrier Bag

a. Materials, tools, and equipment include the following:

- (1) Work table.
- (2) Rags.
- (3) Stencil or rubber type.
- (4) Paint brush.
- (5) Marking ink.
- (6) Solvent.

b. Receive bag from unpacking operation.

c. Examine barrier bag and accept or reject as instructed in TM 9-1375-213-12. Additional instructions are:

d. If markings are obliterated on otherwise undamaged bags, re-mark.

e. If new bags are required:

- (1) Cut two sheets of barrier material for each bag to the full dimensions of original bag.
- (2) Place two cut sheets of barrier material together, plastic facing plastic, and align.
- (3) Seal three edges, using heat sealing machine. Leave wider edge open if bag is not square.

f. Transfer accepted bags to packing operation. If rejected, mark and place in reject area pending disposal.

g. If markings on bag are legible and correct, transfer bag and information to repacking operations.

4-9. Repacking

a. Repack in original manner in accordance with TM 9-1375-213-12.

b. Reseal barrier bag as follows:

- (1) Insert packed inner box(es) into barrier bag in original orientation (indicated by impressions in bag).

- (2) Gently press bag around contents and press sides of open end of bag together to force out excess air.
 - (a) If heat sealer and vacuum pump are available, partially seal open end of barrier bag leaving an opening big enough to insert vacuum pump hose's nozzle.
 - (b) Insert vacuum pump hose's nozzle into opening and run pump until barrier bag is pulled tight against item.
 - (c) Seal open end of bag, using heat sealing machine. Check to see that seal is complete.
- (3) If vacuum pump and heat sealer are not available, seal open end of barrier bag with tape (use PPP-T-60 adhesive tape).
- (4) Fold sealed end in original manner (indicated by impressions in bag).

c. Seal and strap packing box as follows:

- (1) Material, tools and equipment include the following:
 - (a) Conveyor.
 - (b) Strapping and sealing kit: 5/8 inch wide x 0.02 inch thick strapping.
 - (c) Hand lead seal press/steel seal crimping pliers.
 - (d) Seal wires and seals/one-piece steel seals.
 - (e) Leather palm gloves.
 - (f) Face shield or safety goggles.
- (2) Repack boxes as prescribed in TM 9-1375-213-12.
- (3) Pass seal wire (or thin section of steel seal) through eye in swivel and back through eye in hasp. On wire-bound box, pass seal through smaller wire loop twice and beneath adjacent wire that is stapled to box.

- (4) Draw end of wire through hole in seal and pull taut to remove slack. Place mating steel seal sections together.
- (5) Conceal end of wire in lead seal and crimp seal with hand lead seal press. Use crimping pliers to crimp steel seal.
- (6) Repeat operation to seal remaining hasp and swivel, if present.

NOTE

Steel strapping is required for shipment of wooden boxes and for overseas shipment of wirebound boxes. Boxes packed with less than full unit quantities must be color coded (para 4-10) before being strapped.

- (7) If necessary to strap box, assemble and secure steel strapping tightly around box, using hand strapping machine. Do not obstruct marking. Repeat operation, if necessary, to apply second strap.
- (8) Transfer sealed and strapped box to palletizing operation.

4-10. Palletizing

- a. Receive boxes from repacking operation.
- b. Palletize in accordance with method illustrated in figure 4-2 or specific palletization drawings if available..
- c. Normally not more than one ammunition lot will be stored on any one pallet. However, to utilize space, more than one lot of the same type ammunition may be stored on one pallet, if properly identified.
- d. Inspect palletized units to assure pack complies with standards. Complete check and sign off sheet.
- e. Transfer pallets to storage or shipping site.

GENERAL NOTES

1. UNIT SHOWN HEREON IS PREPARED TO MEET THE FOLLOWING REQUIREMENTS:
 - A. GROSS WEIGHT APPROX. 2000 LBS. NOT TO EXCEED 2200 LBS.
 - B. HEIGHT OF PALLET AND LOAD NOT TO EXCEED 52"
 - C. OVERHANG AVOIDED WHERE POSSIBLE, BUT SHOULD NOT EXCEED APPROX. 1" IN ANY DIRECTION. ONE INCH, TWO INCH, OR FOUR INCH BAT-TENS MAY BE USED AS REQUIRED.
 - D. BOXES SECURED TO THE PALLET BY STEEL STRAPPING 1 1/4" X .035, TYPE I, CLASS A OR B, FED SPEC QQ-S-781A.
 - E. STRAPPING SECURED BY ONE 1 1/4" SEAL SECURED WITH A DOUBLE CRIMP, FED SPEC QQ-S-766.
2. A MINIMUM OF 2 STAPLES WILL BE USED TO FASTEN EACH STRAP TO ITS BATTEN. STAPLES WILL NOT BE USED WITHOUT BAT-TENS. STAPLES AUTHORIZED ARE 1 3/8" X 3/4".
3. ADDITIONAL BANDING MAY BE USED IN ANY DIRECTION ON THE PALLET LOAD. AT THE DISCRETION OF THE SHIPPER.
4. FILLERS, CONSTRUCTED OF TWO INCH LUMBER, MAY BE USED TO COMPLETE PARTIAL LAYERS ON PALLET. FILLERS SHOULD BE PLACED ON INTERIOR OF TOP LAYER, WHENEVER PRACTICAL.

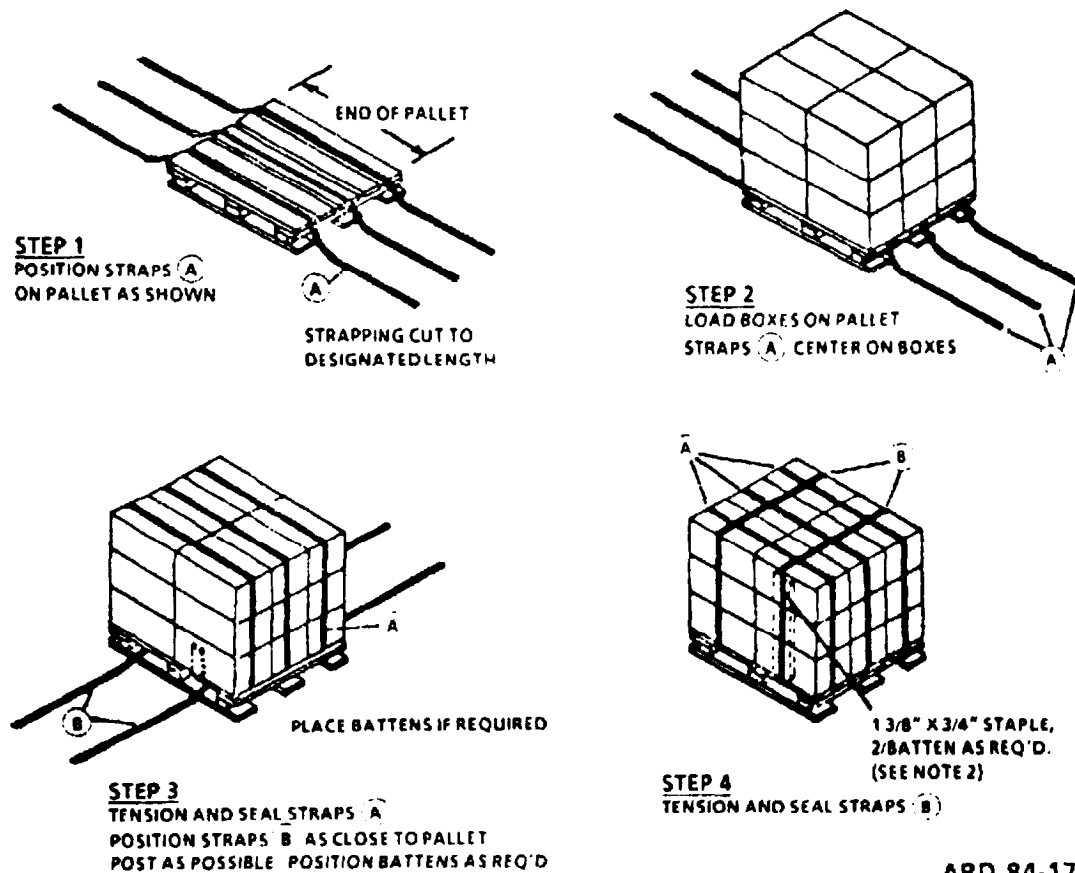

ARD 84-1753

Figure 4-3. Palletizing.

4-11. Special Procedure for Cleaning and Repacking of 15-pound Shaped Charges

a. *Introduction.* Older 15-pound shaped charges can exhibit a “powdering-out” of the explosive filler, especially if they have experienced extensive vibration due to transport by truck or train. As long as the glass liner is intact the charges will still function normally but the powdered explosive must be cleaned up and prevented from contaminating trucks and other materials handling equipment. The explosive powder is flammable and must be handled carefully

b. *Safety Considerations.* Powdering-out charges in boxes without barrier bag lining must not be transported any more than absolutely necessary, and the truck bed must be wet-mopped immediately after it is used for transporting such charges. Charges in boxes with barrier bag lining may be transported locally prior to cleaning. All personnel who have contact with the loose powder from leaking charges must wear coveralls and must wash off their shoes and hands immediately after the operation. Coveralls should be removed and washed after the operation. Personnel must not smoke while wearing coveralls that may be contaminated with the explosive powder. Rags used in the operation must be destroyed afterwards. Standard safety procedures for operations with explosives apply (see TM 9-1300-206). Safety shoes and leather-palmed gloves must be worn when handling boxes and steel strapping.

c. *Procedure.*

- (1) Transport charges to operating area. Wet-mop truck bed afterward, if necessary (see b. *Safety Considerations*).
- (2) Inspect each box for powder leakage. Wipe the exterior of the box with a water-dampened rag if there is any powder evident.
- (3) Cut any steel straps from the boxes using a strapping cutter.
- (4) Cut off seal and open box. If a barrier bag is present, unfold and slit bag open along the top seam.
- (5) Carefully lift out charges and stand-offs, and place on a clean surface.
- (6) If present, remove barrier bag and cardboard box, and empty any loose powder into a holding vessel (a large coffee can with an inch of

water in the bottom and a fitted plastic lid is acceptable).

- (7) Empty any loose powder from the wooden box into a holding vessel.
- (8) Wipe down interior of boxes, cardboard spacers, and barrier bag with a water-dampened rag to remove all loose particles of explosive. Rinse rag(s) frequently in a vessel of water. Wash rubberized horsehair packing in running water.
- (9) Wipe down all surfaces of charges and stand-offs with a water-dampened rag to remove all loose particles of explosive. Rinse rag(s) frequently in a vessel of water.
- (10) Allow all wiped-down items to thoroughly air dry.
- (11) Repack charges in original manner in cardboard box and barrier bag if they were used. Fold bag tightly against box to remove excess air before final sealing. The area of the barrier bag to be heat-sealed must be conspicuously clean and free of explosive residue or film. Heat-sealing equipment and operations must comply with TM 9-1300-206. If a heat sealer is not available, use 2-inch wide PPP-T-60 tape to seal barrier bag. Repack items in original box in original manner.
- (12) If charges were not originally packed in barrier bags it will be necessary to barrier bag them in repacking. Obtain sufficient scrap cardboard to line the charge boxes on hand and MIL-B-131 barrier material sufficient to cover the cardboard liners. Cut and assemble the pieces of cardboard into box liners using PPP-T-60 tape. Fold the barrier material around the liner box and form a bag leaving one edge unsealed so the charges can be packed within the liner box. If a heat sealer is not available, use PPP-T-60 tape. Place the bagged liner box in the wooden box so there is access to the interior. Position the charges in the liner box in the same manner that they were positioned in the original wooden box with the padding between charges. Fold barrier bag flush against liner box before making final seal to remove excess air. Close latch and seal wooden box in original manner.

- (13) Cut or assemble stencil to give the following information: "Charges cleaned and repacked-date. Limit transportation to minimum necessary"
 - (14) Use stencil ink and brush or black spray paint to stencil box.
 - (15) Annotate Ammunition Data Card(s) with "locally cleaned and repacked date, installation name, and unit designation."
 - (16) Designate the repacked charges for priority of issue.
 - (17) The explosive powder gathered from the cleaning operation and the contaminated rag cans and water must be disposed of in a safe and efficient manner that is in compliance with TM 9-1300-206. Keep the explosive powder water wet in vessels with lids until at the site for disposal. Disposal of the explosive powder, vessels, rags, and water should be done by experienced personnel on an EOD or demolition range in accordance with local EPA regulations. Destruction of the item may be undertaken as follows:
 - (a) Dump the items out into a burning pan.
 - (b) Allow the water to evaporate.
 - (c) Saturate the material with diesel fuel oil.
 - (d) Ignite the oil remotely.
- d. When box is dry, re-mark box as diagrammed in b. above.
 - e. Count quantity of items in box and mark number on box in the same position as the original quantity figure.
 - f. Stencil the words LIGHT BOX on each side of box, using approximately the same size letters as original markings.

NOTE

Re-marking may be avoided by applying masking tape on markings (except quantities) prior to painting box.

4-13. Blasting Machine Maintenance

NOTE

- The only maintenance authorized on current blasting machines (the M34 and M32) is an occasional drop of oil on the plunger and replacement of the handle. Both of these operations are authorized at crew level (see TM 9-1375-213-12). Higher level maintenance is still authorized at DS/GS level on the older machines because of a short supply of the newer machines (as of 1995). It may be difficult to obtain one of the newer machines in some locations, so extending the life of the older machines may be necessary
- The following procedures for repair of older model blasting machines are included for reference when necessary to have a machine repaired at a local shop that repairs electric motors or automotive generators and alternators. These procedures should only be used by personnel experience in electric motors and generators. They are being maintained in this TM because the modern replacement item, the M34 (as of 1995) is a backordered item. It may, therefore, be necessary to extend the lives of older machines. The need for blasting machines will diminish as the new, Modern Demolition Initiator (MDI) components become available for general use. The critical parts for the older blasting machines are carbon brushes. Although no longer available in the

This operation may be combined with other similar destruction operations.

4-12. Color Coding Boxes With Light Loads

Boxes with less than full contents will be painted orange as follows:

- a. Check contents with markings on box to verify that nomenclature and lot number are correct.
- b. Refer to tables 4-1 and 4-2 and figure 4-1 for markings and location of markings on boxes.
- c. Apply orange enamel to all outer surfaces of box. If enamel is not available, use orange lacquer.

supply system, the carbon brushes are standard sizes and may be available in military or civilian shops that repair electric motors.

a. General. Blasting machines are received in two conditions—unused machines needing serviceability confirmation, and unserviceable machines.

- (1) For unused machine, operate to loosen it mechanically and then tear down only far enough to determine if any internal corrosion is present, and lubricate as necessary
 - (a) If corrosion is present, sand, clean with solvent, and, if corrosion is not near the commutator, rub with grease.
 - (b) Carefully check stator assemblies, which are mostly iron, for corrosion.
 - (c) After servicing, check for serviceability through use or with checkout devices.
- (2) For unserviceable blasting machine, test machine in accordance with paragraph 3-5b (5), chapter 3, TM 9-1375-213-12. If machine is inoperable, troubleshoot the machine per table 4-3. If machine is operable, clean and service per b. below.

b. *Cleaning, Service, and Repair of Blasting Machines.*

- (1) General.

NOTE

Guidelines below refer to all blasting machines except blasting machines M32, and 34 which are not to be disassembled or repaired.

(a) The gear sector and stud for older (Fidelity-type) 10-cap blasting machines is in the supply system as a repair part. However, this part (because it is of softer metal than the gears in the newer Dixson machines) may not be used to repair a newer machine, since it would not last long when used with the harder gears of the newer machines.

(b) In rebuilding a blasting machine by cannibalizing others, take care to

ensure interchangeability of parts being salvaged. This should present little problem because only a few companies manufactured most of the machines, but personnel must take the time to insure that the part being replaced is identical to the original.

(c) When brushes are salvaged from one machine for use in another, make sure contact surfaces are buffed before installation.

(d) When an armature is salvaged from one machine for use in another, make sure commutator is buffed and mica insertions between segments are undercut. Also, always clean shaft-bearing areas and supply fresh oil before installation.

- (2) *10-cap machines.*

NOTE

- This procedure is applicable to all 10-cap blasting machines except blasting machine M32. Because the internal components of the M32 10-cap machine are totally encapsulated, no maintenance above operator level is required or authorized. If an M32 machine is found defective, it should be disposed of in accordance with local materiel accounting procedures.
- Refer to figures 4-3 and 4-4 as a guide in cleaning and servicing procedure below. Figure 4-3 shows an exploded view of the older (Fidelity-type) 10-cap blasting machine. The internal configuration of the newer model (Dixson) machine is almost identical, except that some components are slightly larger and differently proportioned. In addition, newer model (Dixson) machines have a safety circuit in place of the microswitch shown.

(a) Materials, tools, and equipment include the following:

1. Solvent.

NOTE

Use of Diesel oil, gasoline, trichloroethane, or benzene (benzol) for cleaning is prohibited.

- 2. Clean, lint-free cloths.
- 3. Lubricating oil.
- 4. General purpose grease.
- 5. A sheet of flint abrasive

NOTE

No. 00 fine sandpaper may be substituted for flint abrasive paper. Emery cloth, however must not be used.

paper 2/0.

Table 4-4. Troubleshooting for Blasting Machines

Symptom	Probable cause	Corrective action
10-CAP GENERATOR-TYPE MACHINES		
Fails to operate when actuated.	a. No electrical output	Check for shorted, broken or loose internal wires and repair.
	b. Dirty commutator	Clean and buff (para 4-11b(2)).
	c. Dirty or worn brushes	Buff or replace brushes (para 4-11b(2)).
	d. Moisture inside machine	Dry with clean lintless cloth.
	e. Parts not assembled properly	Disassemble machine and reassemble (para 4-11b(2)).
	f. Broken gear	Replace gear (para 4-11b(2)).
	g. Sheared pin	Replace pin (para 4-11b(2)).
Key fails to turn.	Broken gear tooth	Replace gear (para 4-11b(2)).
Noises or binding.	a. Gear sector and stud broken	Replace gear sector and stud (para 4-11b(2)).
	b. Rough gear teeth	Remove nicks and burs or replace gear (para 4-11b(2)).
	c. Dry bearing	Lubricate with a few drops of oil.
	d. Worn bearing	Reverse bearing.

Table 4-4. Troubleshooting for Blasting Machines - Continued

30-, 50- and 100-CAP GENERATOR-TYPE MACHINES		
Fails to operate when actuated.	a. No electrical output	Check for shorted, broken, or loose internal wires.
	h. Dirty or worn brushes	Buff or replace brushes (para 4-11b(3)).
	c. Dirty commutator	Clean and buff commutator (para 4-11b(3)).
	d. Broken or extremely worn gear or any other major component	Send machine to depot for salvage by cannibalization.
Plunger will not move.	Broken or extremely worn gear or any other major component	Send machine to depot for salvage by cannibalization.
Noises or binding.	a. Rough gear teeth	Smooth burs, gashes, etc. (para 4-11b(3)).
	b. Dry bearing	Lubricate with a few drops of oil (both bearings).
	c. Worn bearing	Send machine to depot for salvage by cannibalization.

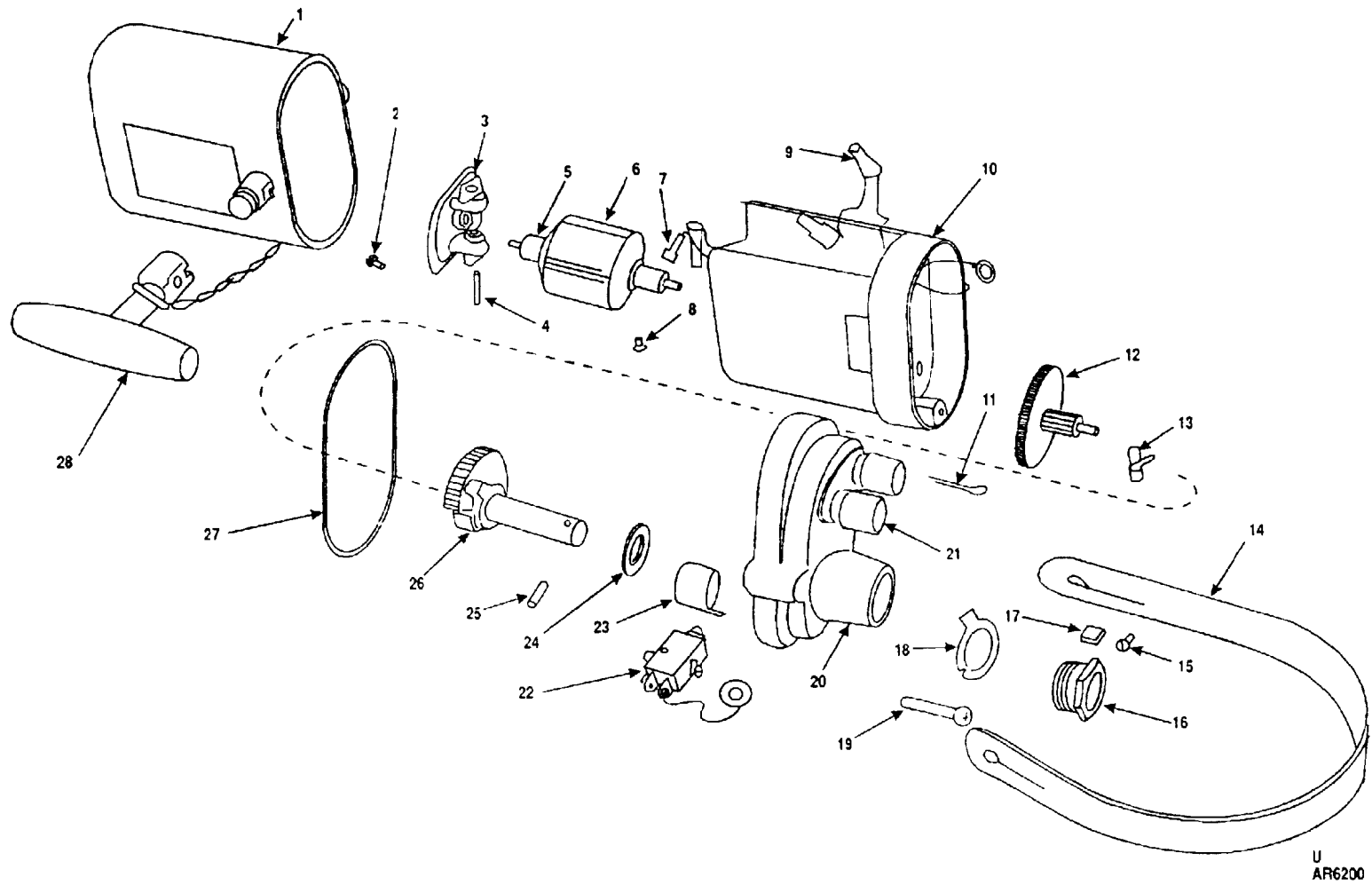

Figure 4-4. Fidelity-type 10-cap blasting machine - exploded view.

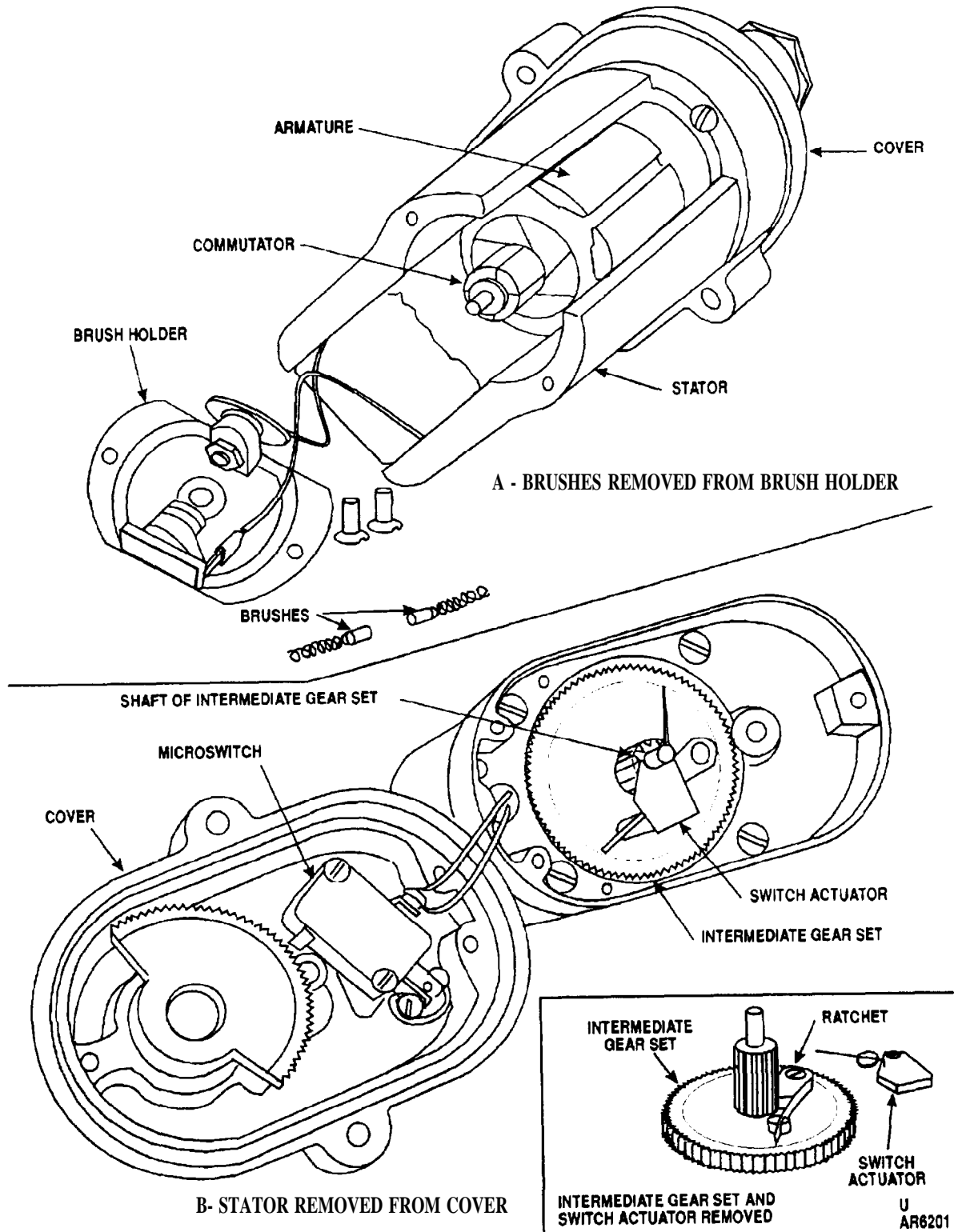

Figure 4-5. Fidelity-type 10-cap blasting machine - partially disassembled.

- 6. Neat's-foot oil.
- 7. A roll of fresh cellophane tape.

NOTE

No other type of tape except cellophane should be used and tape must be fresh.

- 8. A screwdriver.
 - 9. An electrician's knife.
 - 10. A roll of electrical tape.
 - 11. Soap and water.
 - 12. Soldering iron.
 - 13 Rosin core solder.
- (b) After removing leather strap, clean handle and exterior of machine with a cloth dampened (not saturated) with solvent. Use soap and water (not solvent) to clean leather strap and wipe dry immediately.
 - (c) Inspect machine case for cuts or holes and any damage which would preclude sealing of cover and case. If such damage is present, replace strap and ship machine to a depot for salvage by cannibalization.
 - (d) Insert handle and turn it to see if mechanism is in working order. If handle cannot be turned without exerting undue force or if unusual noises result when the handle is turned, make note of defect, check troubleshooting chart (table 4-3), and correct as indicated below.
 - (e) Remove the two screws securing case to cover and pull off cover (with attached parts). If any dents are present in case, remove them by pushing or pounding them out from inside.
 - (f) Remove brush holder and service brushes as follows:

- 1. Remove the screws holding brush holder to stator, carefully pull brush holder away from stator, and remove brushes, taking care not to let spring-loaded brushes escape.
- 2. Hold flint paper, grit up, on a flat surface and gently rub contact surface of each brush on grit, while holding brush perpendicular to paper.

NOTE

One or two short passes should be sufficient to clean brush and flatten contact surface.

- 3. Wipe brushes clean with a clean, soft cloth.
- 4. Measure length of brush from contact surface to shoulder of brush.
 - a. If length is less than $\frac{3}{32}$ inch for either brush, replace both brushes (and springs) with new ones, if available, and discard old brushes (and springs).

NOTE

If new brushes are not available, old brushes with length of at least $\frac{1}{32}$ inch may be used until new brushes are ordered and received. If brushes with length less than $\frac{3}{32}$ inch are used, put a tag on machine instructing user to return machine when new brushes are in stock.

- b. If brushes have a length less than $\frac{1}{32}$ inch, and no replacement brushes are available complete procedures below and set machine aside until replacement brushes are obtained.

- (g) Remove and service armature as follows:

NOTE

Armature gear is serviced at the same time that other gears are serviced ((j) below).

1. Pull armature out of stator.
2. Wipe off commutator with a clean cloth and inspect it for ground-in brush deposit, dirt, pits, and heavy wear.
3. If any of above conditions are found, use flint abrasive paper to buff commutator surface evenly all the way around to correct condition.
4. After buffing surface, slightly undercut mica insulation between segments, using edge of a folded piece of flint abrasive paper.
5. With crocus cloth or an abrasive paste (rubbing compound), remove any significant rust from laminated iron periphery of armature. Take care not to scratch commutator or leave paste on any portion of armature. Wipe armature with clean, soft cloth to remove any remaining grit.

- (h) Clean and service stator as follows:

1. Clean any rust from stator and wipe clean as described in (g) 5. above.
2. Carefully inspect all visible stator lead wires for cuts, breaks, shorts; etc. Repair as necessary, using rosin core solder to splice wires and using electrical tape to insulate.

- (i) Free stator and intermediate gear set as follows:

1. Remove the three screws holding stator to cover, taking care not to damage stator leads nearby.

2. Slowly and carefully remove stator from cover.

NOTE

As an aid in reassembly, carefully note arrangement and relationship of intermediate gear set and switch actuator.

3. Pull shaft of intermediate gear set from its bearing hole.

- (j) Clean and service gears as follows:

1. Inspect teeth of all gears (including armature gear) for burs and gouges. Using screwdriver or knife blade, smooth gear teeth as necessary.

NOTE

A small file may be used to smooth gear teeth, but care must be exercised in using it because the gears are made of soft metal and can be easily damaged.

2. Remove any rust or corrosion from gears as described in (g) 5. above.

3. Wipe old grease from parts and spread fresh grease on gear teeth, and in and around bearing surfaces. Work mechanisms to make sure grease is distributed properly.

NOTE

Older (Fidelity-type) machines may be repaired by replacement of the gear sector and stud (see procedure in (k) below), since this repair part is in the supply system. However, this part (because it is of softer metal than the gears in the newer Dixson machines) may not be used to repair a newer machine, since it would not last long when used with the harder gears.

- (k) If gear sector of an older machine is severely damaged, replace it as follows:

NOTE

If machine has a C ring, it is necessary to remove screw holding it and rotate both C ring and hollow hex-head bolt before headless straight pin may be driven out in procedure below.

1. Push out or drive out headless pin and remove sector gear from cover.
2. Reassemble new sector gear to cover and secure with headless straight pin. Inspect headless pin for extreme wear or breakage. Obtain a replacement for use during reassembly if necessary.

NOTE

Ensure that all parts are assembled in proper order and manner (figs. 4-2 and 4-3).

- (l) Inspect gasket in peripheral notch in cover and replace if necessary.
- (m) Reassemble intermediate gear set to stator.
- (n) Reassemble stator (and assembled parts) to cover as follows:
 1. Push down on and rotate sector gear one full turn clockwise against tension of return spring until its flat side is parallel to longer side of cover.
 2. While holding gear sector in position, fit stator (and assembled parts) carefully into cover and secure with screws removed in (i) 1. above.

3. Make sure mechanism just assembled works properly by inserting handle and twisting a few times.

- (o) Place a drop of oil into both holes that armature shaft fits into (i.e., shaft hole in stator and shaft hole in brush holder).
- (p) Slide armature (gear end first) into stator so that shaft does not go into its appointed hole, but butts against surrounding plate.
- (q) Assemble brushes to brush holder as follows:
 1. Fit brushes to their springs and insert into recesses in brush holder.
 2. Cut two 4-inch pieces of fresh cellophane tape and temporarily secure each brush into its recess with tape end.

NOTE

Use only fresh cellophane tape for temporarily securing brushes. Old cellophane tape, or other types of tape, may leave a deposit. Use of tape makes assembly of brush holder, with its spring-loaded brushes, to stator quite easy.

- (r) Reassemble brush holder and armature to stator as follows:
 1. Place brush holder over protruding end of armature, inserting armature shaft into shaft hole in brush holder.
 2. Pull tape out to release brushes. Make sure no tape remains on brushes.
 3. Carefully rotate armature so that shaft on other end fits into its hole in stator and then secure brush holder with screws removed in (o) 1. above (two or four screws, depending on model of machine).
 4. Make sure mechanism works properly and armature does not bind.

- (s) Reassemble case to cover, using screws removed in (e) above.
 - (t) If necessary, paint case and cover using an appropriate colored enamel. Do not paint near terminals or handle hole and do not paint brass nameplate.
 - (u) After paint has dried, treat leather strap with neat's-foot oil and refit it to machine.
 - (v) Subject machine to serviceability test.
 - 1. If machine passes serviceability test, return it to field use.
 - 2. If machine does not pass serviceability test, ship to a depot for salvage by cannibalization.
- (3) 30-, 50- and 100-cap machines.

NOTE

- This procedure is not applicable to the M34 50-cap blasting machine. No maintenance above operator level is required or authorized, since the internal components are totally encapsulated. If an M34 machine is found defective it should be disposed of in accordance with local materiel accounting procedures.
- Refer to figure 4-5 and 4-6 as a guide in cleaning and servicing procedure below. Figure 4-5 is an exploded view of a plunger-type blasting machine. The only major difference between the plunger-type machines, besides their size, is that the newer 50-cap machines have a safety circuit instead of a switch assembly.

- (a) Obtain the following items:

1. About 1/2 pint of solvent suitable for use on electrical equipment.

NOTE

Use of diesel oil, gasoline, trichloroethane, or benzene (benzol) for cleaning is prohibited.

- 2. Clean, lint-free cloths.
- 3. General purpose lubricating oil.
- 4. General purpose grease.
- 5. Flint abrasive paper.

NOTE

No. 00 fine sandpaper may be substituted for the flint abrasive paper. Emery cloth, however, must not be used.

- 6. Neat's-foot oil.
- 7. Screwdriver.
- 8. Electrician's knife.
- 9. Roll of electrical tape.
- 10. Soap and water.

NOTE

A soldering iron and rosin core solder may also be required during the operation.

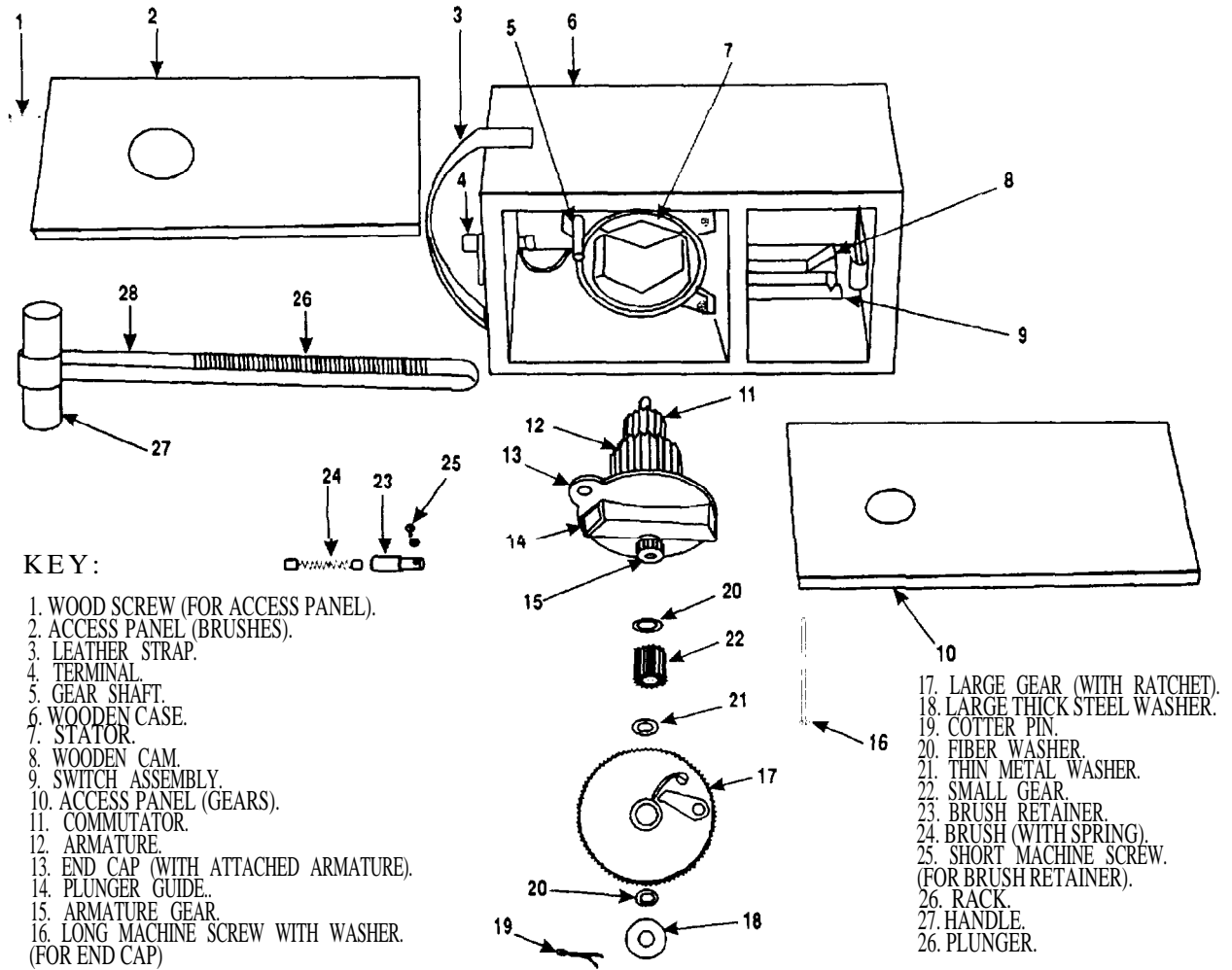

Figure 4-6. Fifty-cap blasting machine - exploded view.

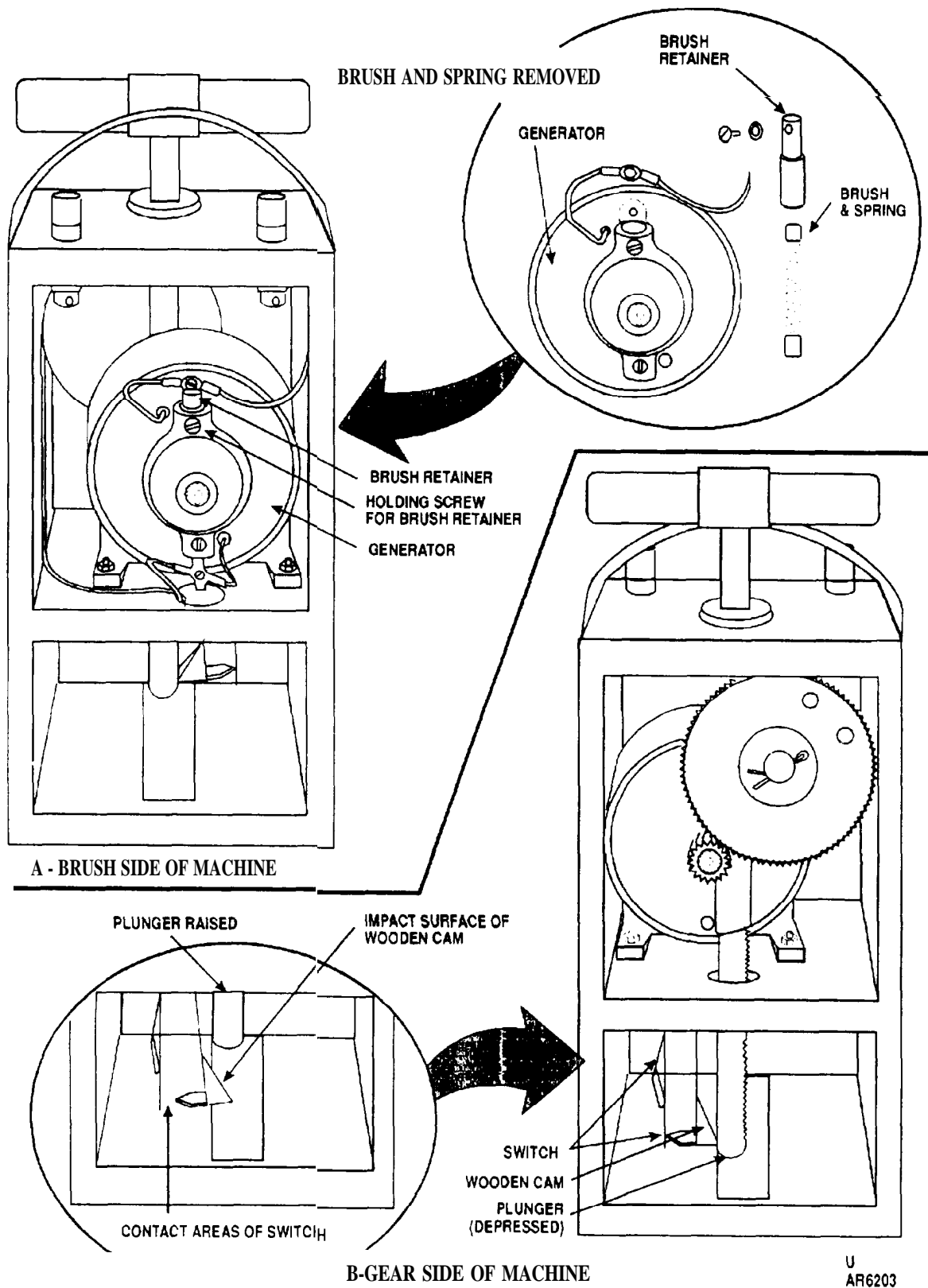

Figure 4-7. Fifty-cap blasting machine - partially disassembled.

- (b) After removing leather strap, wash case and wooden handle with cloth dampened (not saturated) with soap and water. Do not splash water into plunger hole. Wipe off machine with clean, damp cloth to remove soap, then dry thoroughly with a clean, dry cloth. Use soap and water to clean strap, and wipe dry immediately.
- (c) Inspect wooden case for severe damage. If a panel requires replacement, arrange for DS box repair personnel to make panel for replacement in (1) 12. below. If no car enter shop facilities are available, finish procedure below, then ship machine to a higher maintenance level where such facilities are available. If broken woodwork precludes any use of machine, take no further action except to ship machine to a depot for salvage by cannibalization.

NOTE

If leather carrying strap is severely damaged or broken, repair or replace with any suitable locally available materials.

- (d) Remove both access panels from machine.
- (e) Move plunger up and down and observe drive mechanism to see if it is working properly. If there is any binding, or if components are disconnected, make note of defect and correct in steps below.
- (f) Carefully remove brush retainers and service brushes as follows:
 - 1. Remove brush retainers and withdraw spring-loaded brushes, taking care not to let brushes escape.
 - 2. Hold flint paper, grit up, on a flat surface and gen-

tly rub contact surface of each brush on grit, while holding brush perpendicular to paper.

NOTE

One or two short passes should be sufficient to clean brush and flatten contact surface.

- 3. Wipe brushes clean with a clean, soft cloth.
- 4. Measure length of brush from contact surface to shoulder brush. If length is less than 1/32 inch for either brush, replace both brushes.

NOTE

Brushes for these machines are not stock items because of their low use rate and long life. However, these brushes may be obtained by direct order from the manufacturer or they may be salvaged from damaged machines.

- (g) Remove and service armature as follows:
 - 1. Remove cotter pin from gear shaft and pull off large and small gears and all four related washers (fig. 4-4). If a washer is not readily apparent, it may be stuck to a gear or the end cap.
 - 2. Pull out rack.
 - 3. Remove screws securing it and take off end cap and attached armature.
 - 4. Wipe off commutator with a clean cloth and inspect it for ground-in brush deposit, dirt, pits, or heavy wear.

5. If any of above conditions are found, use flint abrasive paper to buff commutator surface evenly all the way around to correct condition.
 6. After buffing surface, slightly undercut mica insulation between segments, using edge of a folded piece of flint abrasive paper.
 7. With crocus cloth or an abrasive paste (rubbing compound), remove any significant rust from laminated iron periphery of armature. Take care not to scratch commutator or leave paste on any portion of armature. Wipe armature with clean, soft cloth to remove any remaining grit,
- (h) Clean and service stator as follows:
1. Clean any rust from stator and wipe clean as described in (g) 4. and 5. above.
 2. Carefully inspect all visible wiring for cuts, worn insulation and loose connections. Repair, as necessary, using rosin core solder to splice wires and using electrical tape to insulate.
- (i) Place a drop or two of oil on end shafts of armature, and insert it back into the stator. Secure armature with end cap and screws, making sure end shafts are properly seated, and armature is free to rotate in its bearings.
- (j) Clean switch contact areas with solvent, and buff with flint paper. Wipe off with a clean cloth.
- (k) Clean and service gears as follows:
1. Inspect gear teeth (on R rack and pinion gears) for burs, gashes; etc. Using a screwdriver or knife blade, smooth gear teeth, as necessary.
 2. Wipe grease from gears, rack, and impact surface of wooden cam on switch assembly. Apply fresh grease sparingly to rack, gears, and impact surface of wooden cam.
- (1) Reassemble machine as follows:
1. Insert plunger into its guide.
 2. Grease sparingly both sides of a fiber washer and push washer all the way back on gear shaft.
 3. Ensure that thin metal washer is not stuck to small gear and place small gear on gear shaft.
 4. Grease the thin metal washer sparingly and place it on gear shaft.
 5. Hold large gear ratchet spring back and swing ratchet back (away from center hole of gear) so that it holds the spring in this position.
 6. While holding ratchet back, place large gear on gear shaft (ratchet toward generator) so that it butts against thin metal washer and small gear and engages armature gear.
 7. Grease sparingly remaining fiber washer and place it on gear shaft.
 8. Place large thick steel washer on gear shaft.
 9. Insert cotter pin in hole at end of gear shaft and spread prongs to secure.

- 10 Work plunger up and down a few times to make sure mechanism is in good working order. If mechanism does not work properly and cannot be fixed by adjustment or simple repair, cannibalize serviceable machine components for use in repair of similar models.
 11. Resecure brushes and springs in their holders.
 12. Resecure access panels to machine.
- (m) Apply a coat of varnish or paint to wooden case of machine and wooden handle, if necessary. Make sure case is clean and dry before varnishing. Take care not to get varnish on terminals, plunger, or plunger guide.
 - (n) After varnish has dried, treat leather strap with neat's-foot oil and refit it to machine.
 - (o) Conduct a serviceability test on machine. If machine fails test, cannibalize serviceable machine components for use in repair of similar models.

THIS PAGE INTENTIONALLY LEFT BLANK

**APPENDIX A
REFERENCES**

A-1. Scope

This appendix lists all forms and publications referenced in this manual.

A-2. Administrative Publications

Consolidated Index of Army Publications and Blank Forms	DA Pam 25-30
The Army Maintenance Management System (TAMMS)	DA Pam 738-750

A-3. Army Regulations

Malfunctions Involving Ammunition and Explosives	AR 75-1
--	---------

A-4. Technical Manuals

Ammunition and Explosives Standards	TM 9-1300-206
Ammunition Maintenance	TM 9-1300-250
Operator's and Unit Maintenance Manual (Including Repair Parts and Special Tools List) for Demolition Materials.	TM 9-1375-213-12

A-5. Forms

Recommended Changes to Publications and Blank Forms	DA Form 2028
Ammunition Condition Report	DA Form 2415

A-6. Miscellaneous Publications

Sets, Kits, and Outfits Tool Set, Ammunition: Direct Support, General Support Ordnance Company, Ammunition.	SC 4940-95-A11
---	----------------

A-7. Surveillance Bulletins

Ammunition Surveillance Procedures	SB 742-1
Igniter, Time Blasting Fuse: Weatherproof, M2; Surveillance Function Test. . .	SB 742-1375-20
Firing Device, Demolition: M1 Series, Pressure Type; Surveillance Function Test	SB 742-1375-24
Firing Device, Demolition: M1, Release Type and M5, Pressure Release Type: Surveillance Function Test	SB 742-1375-25
Firing Device, Demolition: M1, Pull Type and M3, Pull Release Type	SB 742-1375-26
Detonator, Percussion: M1A2, 15-Second Delay and M2A1, 8-Second Delay....	SB 742-1375-41
Ammunition Surveillance Procedure for USAMICOM Materiel: Explosive Bolt 10022224 for Guided Missile Launcher Helicopter Subsystem, M22. . . .	SB 742-1375-92-001
Ignition Cylinder, Portable Flame Thrower, M1; Ammunition Surveillance Procedures	SB 742-1375-94-4
Ammunition Surveillance Procedure: File Destroyer, Incendiary, ABC-M4	SB 742-1375-94-5
Igniter, Document Destroyer, Incendiary, M25; Ammunition Surveillance Procedure	SB 742-1375-94-6

TM 9-1375-213-34&P

Document Destroyer, Emergency, Incendiary, M3; Ammunition Surveillance Procedure	SB	742-1375-94-7
Charge, Demolition: Block, M3, M5A1, M112, and Charge Assembly, Demolition: M37 Series or M183	SB	742-1375-94-423
Igniter, Time Blasting Fuse: Weatherproof M60; Surveillance Function Test..	SB	742-1375-94-434
Document Destroyer, Emergency Incendiary: M4; Ammunition Surveillance Procedures.	SB	742-1375-94-800
Cryptographic Equipment Destroyer Incendiary, TH1/TH4, M1A1, M1A2, and M2A1 Ammunition Surveillance Procedures	SB	742-1375-94-801
Cap, Blasting: Special Nonelectric, Ammunition Surveillance Procedures	SB	742-1375-94-821
Cap, Blasting: Electric, Ammunition Surveillance Procedures	SB	742-1375-94-822
Firing Device, Demolition Delay Type M1; Ammunition Surveillance Procedures	SB	742-1375-94-840
Firing Device, Multi-Purpose, M142, (1375-M103), Ammunition Surveillance Procedures.	SB	742-1375-94-841
Blasting Machine: 10 Cap, M32 or 50 Cap, M34; Ammunition Surveillance Procedures	SB	742-1375-94-880

APPENDIX B**DIRECT SUPPORT AND GENERAL SUPPORT MAINTENANCE****REPAIR PARTS AND SPECIAL TOOLS LIST****Section I. INTRODUCTION****B-1. Scope.**

This RPSTL lists and authorizes spares and repair parts; special tools; special test, measurement, and diagnostic equipment (TMDE); and other special support equipment required for performance of direct support and general support (DS/GS) maintenance of Demolition Materials. It authorizes the requisitioning, issue, and disposition of spares, repair parts and special tools as indicated by the source, maintenance and recoverability (SMR) codes.

B-2. General.

In addition to Section I, Introduction, this Repair Parts and Special Tools List is divided into the following sections:

a. Section II - Repair Parts List. A list of spares and repair parts authorized by this RPSTL for use in the performance of maintenance. The list also includes parts which must be removed for replacement of the authorized parts. Parts lists are composed of functional groups in ascending alphanumeric sequence, with the parts in each group listed in ascending figure and item number sequence. Bulk materials are listed by item name in FIG BULK at the end of the section. Repair parts for repairable special tools are also listed in this section. Items listed are shown on the associated illustrations.

b. Section III - Special Tools List. Not applicable.

c. Section IV - Cross-reference Indexes. A list, in National item identification number NIIN) sequence, of all National stock numbered items appearing in the listings, followed by a separate list in alphanumeric sequence of all part numbers appearing in the list. National stock numbers and part numbers are cross-referenced to each illustration figure and item number appearance.

B-3. Explanation of Columns (Sections II and III).

a. ITEM NO. (Column (1)). Indicates the number used to identify items called out in the illustration.

b. SMR CODE (Column (2)). The Source, Maintenance, and Recoverability (SMR) code is a 5-position code containing supply/requisitioning information, maintenance level authorization criteria, and disposition instructions, as shown in the following breakout:

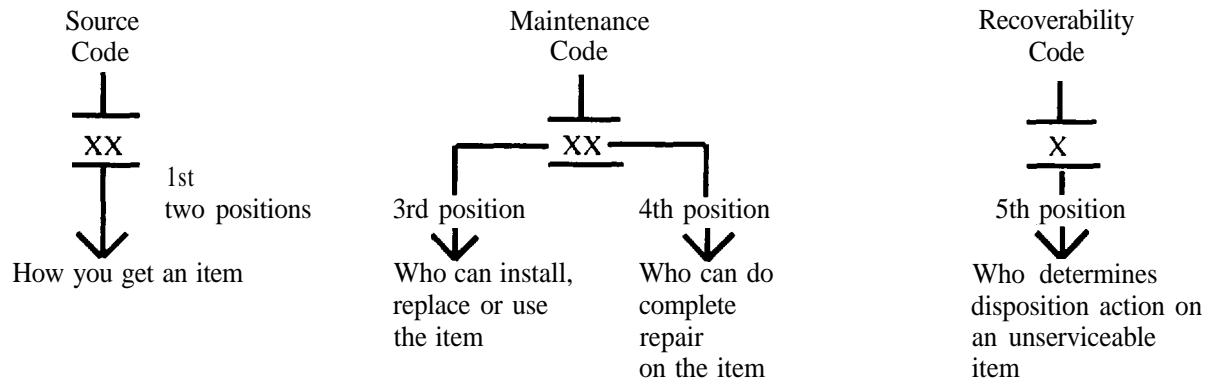

*Complete Repair: Maintenance capacity, capability, and authority to perform all corrective maintenance tasks of the "Repair" function in a use/user environment in order to restore serviceability to a failed item.

(1) Source Code. The source code tells you how you get an item needed for maintenance, repair, or overhaul of an end item/equipment. Source codes are always the first two positions of the SMR code. Explanations of source codes follow:

Code	Explanation
PA PB PC** PD PE PF PG	Stocked items; use the applicable NSN to request/requisition items with these source codes. They are authorized to the level indicated by the code entered in the 3rd position of the SMR code. ** NOTE: Items coded PC are subject to deterioration.
KD KF KB	Items with these codes are not to be requested/requisitioned individually. They are part of a kit which is authorized to the maintenance level indicated in the 3rd position of the SMR code. The complete kit must be requisitioned and applied.
MO-(Made at unit Level) MF-(Made at DS Level) MH-(Made at GS Level) ML- (Made at Specialized Repair Act) (SRA) MD- (Made at Depot)	Items with these codes are not to be requested/requisitioned individually. They must be made from bulk material which is identified by the part number in the DESCRIPTION AND USABLE ON CODE (UOC) column and listed in the Bulk Material group of the repair parts list in this RPSTL. If the item is authorized to you by the 3rd position code of the SMR code, but the source code indicates it is made at a higher level, order the item from the higher level of maintenance.

Code	Explanation
AO-(Assembled by unit Level)	Items with these codes are not to be requested/requisitioned individually. The parts that make up the assembled item must be requisitioned or fabricated and assembled at the level of maintenance indicated by the source code. If the 3rd position code of the SMR code authorizes you to replace the item, but the source code indicates the item is assembled at a higher level, order the item from the higher level of maintenance.
AF-(Assembled by DS Level)	
AH-(Assembled by GS Level)	
AL-(Assembled by SRA)	
AD-(Assembled by Depot)	

XA - Do not requisition an "XA" -coded item. Order its next higher assembly. (Also, refer to the NOTE below.)

XB - If an "XB" item is not available from salvage, order it using the CAGEC and part number.

XC - Installation drawing, diagram, instruction sheet, field service drawing; identified by manufacturer's part number.

XD - Item is not stocked. Order an "XD" -coded item through normal supply channels using the CAGEC and part number given, if no NSN is available.

NOTE

Cannibalization or controlled exchange, when authorized, may be used as a source of supply for items with the above source codes, except for those source coded "XA" or those aircraft support items restricted by requirements of AR 700-42.

(2) Maintenance Code. Maintenance codes tell you the level(s) of maintenance authorized to USE and REPAIR support items. The maintenance codes are entered in the third and fourth positions of the SMR Code as follows:

(a) The maintenance code entered in the third position tells you the lowest maintenance level authorized to remove, replace, and use an item. The maintenance code entered in the third position will indicate authorization to one of the following levels of maintenance.

Code	Application/Explanation
C	- Crew or operator maintenance done within unit maintenance.
O	- Unit level maintenance can remove, replace, and use the item.
F	- Direct support level maintenance can remove, replace, and use the item.
H	- General support level maintenance can remove, replace, and use the item.
L	- Specialized repair activity can remove, replace and use the item.
D	- Depot support level maintenance can remove, replace, and use the item.

(b) The maintenance code entered in the fourth position tells you whether or not the item is to be repaired and identifies the lowest maintenance level with the capability to do complete repair (i.e., perform all authorized repair functions).

NOTE

Some limited repair may be done on the item at a lower level of maintenance, if authorized by the Maintenance Allocation Chart (MAC) and SMR Codes.

Code	Application/Explanation
O	- Unit level is the lowest level that can do complete repair of the item.
F	- Direct support is the lowest level that can do complete repair of the item.
H	- General support is the lowest level that can do complete repair of the item.
L	- Specialized repair activity (designate the specialized repair activity) is the lowest level that can do complete repair of the item.
D	- Depot is the lowest level that can do complete repair of the item.
Z	- Nonrepairable. No repair is authorized.
B	- No repair is authorized. No parts or special tools are authorized for the maintenance of a "B" coded item. However, the item may be reconditioned by adjusting, lubricating, etc., at the user level.

(3) Recoverability Code. Recoverability codes are assigned to items to indicate the disposition action on unserviceable items. The recoverability code is shown in the fifth position of the SMR Codes as follows:

Recoverability codes	Application/Explanation
Z	- Nonrepairable item. When unserviceable, condemn and dispose of the item at the level of maintenance shown in 3rd position of SMR Code.
O	- Repairable item. When uneconomically repairable, condemn and dispose of the item at unit level.
F	- Repairable item. When uneconomically repairable, condemn and dispose of the item at direct support level.
H	- Repairable item. When uneconomically repairable, condemn and dispose of the item at the general support level.
D	- Repairable item. When beyond lower level repair capability, return to depot. Condemnation and disposal of item not authorized below depot level.
L	- Repairable item. Condemnation and disposal are not authorized below specialized repair activity (SRA).

A - Item requires handling of condemnation procedures because of specific reasons (e.g., precious metal content, high dollar value, critical material, or hazardous material). Refer to appropriate manuals/directives for specific instructions.

c. CAGEC (Column (3)). The commercial and Government Entity Code (CAGEC) is a 5-digit numeric code used to identify the manufacturer, distributor, or Government agency, etc., that supplies the item.

d. Part Number (Column (4)). Indicates the primary number used by the manufacturer (individual, company, firm, corporation, or Government activity), which controls the design and characteristics of the item by means of its engineering drawings, specifications, standards, and inspection requirements to identify an item or range of items.

NOTE

When you use a NSN to requisition an item, the item you receive may have a different part number from the part ordered.

e. Description and Usable On Code (UOC) (Column (5)). This column includes the following information:

(1) The Federal item name, and when required, a minimum description to identify the item.

(2) Items that are included in kits and sets are listed below the name of the kit or set.

(3) Spare/repair parts that make up an assembled item are listed immediately following the assembled item line entry.

(4) Part numbers for bulk materials are referenced in this column in the line item entry for the item to be manufactured/fabricated.

(5) The statement "END OF FIGURE" appears just below the last item description in Column (5) for a given figure in Section II.

f. QTY (Column 6). The QTY (quantity per figure column) indicates the quantity of the item used in the breakout shown on the illustration/figure, "V" appearing in this column in lieu of a quantity indicates that the quantity is variable and the quantity may vary from application to application.

B-4. Explanation of Columns (Section IV).

a. NATIONAL STOCK NUMBER (NSN) INDEX.

(1) STOCK NUMBER column. This column lists the NSN by National item identification number (NIIN) sequence. The NIIN consists of the last 9 digits of the NSN.

(i.e., $\frac{\text{NSN}}{5305-01-674-1467}$)
NIIN

When using this column to locate an item, ignore the first 4 digits of the NSN. However, the complete NSN should be used when ordering items by stock number.

(2) FIG. column. This column lists the number of the figure where the item is identified/located. The figures are in numerical order in Section II.

(3) ITEM column. The item number identifies the item associated with the figure listed in the adjacent FIG. column. This item is also identified by the NSN listed on the same line.

b. PART NUMBER INDEX. Part numbers in this index are listed by part number in ascending alpha-numeric sequence (vertical arrangement of letters and number combinations which place the first letter or digit of each group in order A through Z, followed by the numbers 0 through 9 and each following letter or digit in like order).

(1) CAGEC column. The Commercial and Government Entity Code (CAGEC) is a 5-digit numeric code used to identify the manufacturer, distributor, or Government agency, etc., that supplies the item.

(2) PART NUMBER column. Indicates the primary number used by the manufacturer (individual, firm corporation, or Government activity) which controls the design and characteristics of the item by means of its engineering drawings, specifications, standards, and inspection requirements to identify an item or range of items.

(3) STOCK NUMBER column. This column lists the NSN for the associated part number and manufacturer identified in the PART NUMBER and CAGEC columns to the left.

(4) FIG. column. This column lists the number of the figure where the item is identified/located in Section II.

(5) ITEM column. The item number is that number assigned to the item as it appears in the figure referenced in the adjacent figure number column.

c. FIGURE AND ITEM NUMBER INDEX. This index lists the figures in the order in which they appear in Section II.

(1) FIG. column. This column lists the number of the figure where the item is identified/located in Section II.

(2) ITEM column. The item number is that number assigned to the item as it appears in the figure referenced in the adjacent figure number column.

(3) STOCK NUMBER column. This column lists the NSN for the item.

(4) CAGEC column. The Commercial and Government Entity Code (CAGEC) is a 5-digit numeric code used to identify the manufacturer, distributor, or Government agency, etc., that supplies the item.

(5) PART NUMBER column. Indicates the primary number used by the manufacturer (individual, firm corporation, or Government activity), which controls the design and characteristics of the item by means of its engineering drawings, specifications, standards, and inspection requirements to identify an item or range of items.

B-5 Special Information.

a. USABLE ON CODE. The usable on code appears in the lower left corner of the Description column heading. Usable on codes are shown as “UOC:” in the Description Column (justified left) on the first line applicable item description/nomenclature. Uncoded items are applicable to all models. Identification of the usable on codes used in the RPSTL are:

Code	<u>Used On</u>
BMA	Blasting Machine 10-CAP
BMB	Blasting Machine 50-CAP

B-6

b. ASSEMBLY INSTRUCTION. Detailed assembly instructions for items source coded to be assembled from component spare/repair parts are found in the narrative portion of this manual. Items that make up the assembly are listed immediately following the assembly item entry or reference is made to an applicable figure.

c. KITS. Line item entries for repair parts kits appear in a group in Section II (see Table of Contents).

B-6. How to Locate Repair Parts.

a. When National Stock Number or Part Number is Not Known:

(1) First. Using the table of contents, determine the assembly group or subassembly group to which the item belongs. This is necessary since figures are prepared for assembly groups and subassembly groups, and listings are divided into the same groups.

(2) Second. Find the figure covering the assembly group or subassembly group to which the item belongs.

(3) Third. Identify the item on the figure and note the number(s).

(4) Fourth. Refer to the repair parts list for the figure to find the part number(s) noted on the figure.

(5) Fifth. Refer to the figure and item number index to find the NSN, if assigned.

b. When National Stock Number or Part Number is Known:

(1) First. Using the National Stock Number or the Part Number Index, find the pertinent National Stock Number or Part Number. The NSN index is in National Item Identification Number (NIIN) sequence (See B-4.a(1)). The part numbers in the Part Number index are listed in ascending alphanumeric sequence (See B-4.b). Both indexes cross-reference you to the illustration/figure and item number of the item you are looking for.

(2) Second. Turn to the figure and item number, verify that the item is the one you are looking for, and locate the item number in the repair parts list.

B-7. Abbreviations.

All are common.

SECTION II
REPAIR PARTS LIST

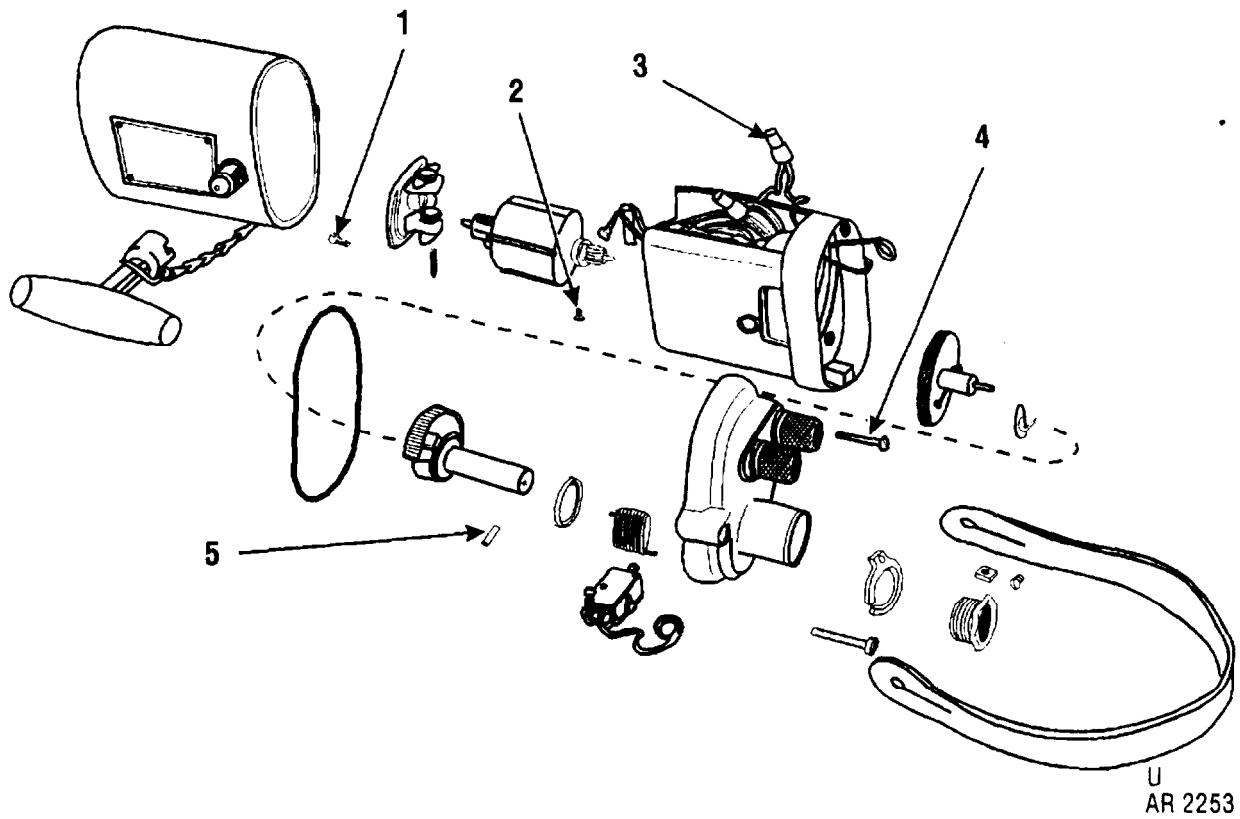

U
AR 2253

Figure B-1. Blasting Machine 10-CAP

Section II

(1) ITEM NO	(2) SMR CODE	(3) CAGEC	(4) PART NUMBER	(5) DESCRIPTION AND USABLE ON CODES (UOC) GROUP 00. BLASTING MACHINE 10-CAP PAPD2657 (19203) BMA FIGURE B-1. BLASTING MACHINE 10-CAP	(6) QTY
1	PBOZZ	96906	MS35190-236	SCREW, MACHINE: 0.138 IN.-32 UNC - 2A UOC: BMA	2
2	PBOZZ	24617	227316	SCREW, MACHINE: UOC: BMA	4
3	PBOZZ	81349	MIL-T-16366	SPLICE, CONDUCTOR: 0.625 OA LG, 14 AWG, UNINSULATED, COPPER OA UOC: BMA	2
4	PBOZZ	96906	MS35206-233	SCREW, MACHINE: 0.138 IN.-32 TPI-2A UOC: BMA	3
5	XDOZZ	50456	757	PIN, STRAIGHT, HEADLESS: UOC: BMA	1

END OF FIGURE

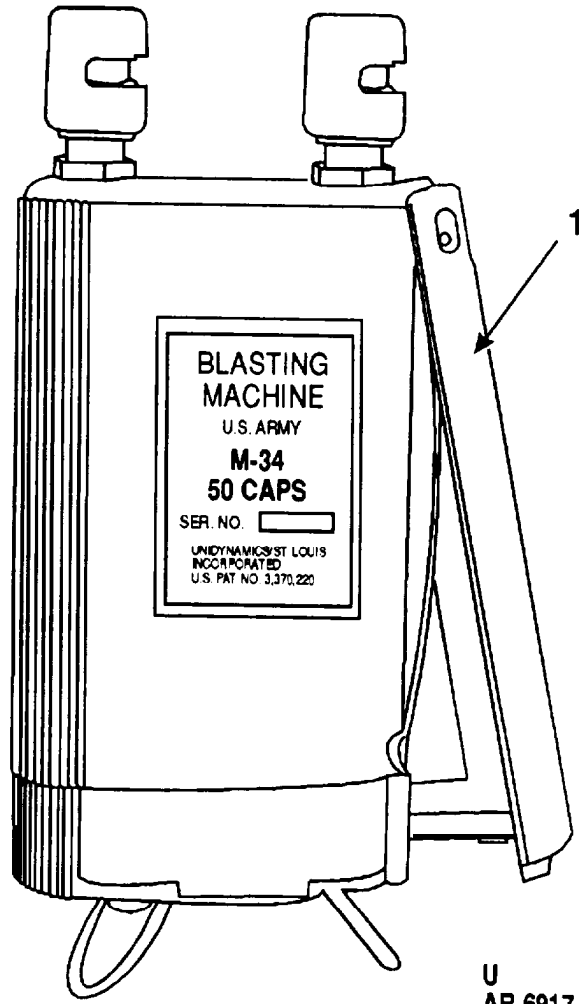

U
AR 6917

Figure B-2. Blasting Machine 50-CAP

Section II

TM 9-1375-213-34&P

(1) ITEM NO	(2) SMR CODE	(3) CAGEC	(4) PART NUMBER	(5) DESCRIPTION AND USABLE ON CODES (UOC)	(6) QTY
				GROUP 01. BLASTING MACHINE 50-CAP 9312773 (19200) BMB	
				FIGURE B-2. BLASTING MACHINE 50-CAP	
1	PAOZZ	19200	9235508	LEVER, MANUAL CONTROL LEVER, MANUAL-CONTROL: BMB	1

END OF FIGURE

SECTION III
SPECIAL TOOLS LIST

Section III. Special Tools List. Not Required.

CROSS-REFERENCE INDEXES

STOCK NUMBER	NATIONAL STOCK NUMBER INDEX		STOCK NUMBER	FIG. ITEM	
	FIG.	ITEM		FIG.	ITEM
5305-00-022-7316	B1	2	5305-00-984-4993	B1	4
5940-00-186-2877	B1	3	5340-01-372-3881	B2	1
5305-00-958-5453	B1	1			

CROSS-REFERENCE INDEXES

CAGEC	PART NUMBER INDEX		FIG.	ITEM
	PART NUMBER	STOCK NUMBER		
24617	227316	5305-00-022-7316	B1	2
50456	757		B1	5
19200	9235508	5340-01-372-3881	B2	1
81349	MIL-T-16366	5940-00-186-2877	B1	3
96906	MS35190-236	5305-00-958-5453	B1	1
96906	MS35206-233	5305-00-984-4993	B1	4

APPENDIX C

EXPENDABLE AND DURABLE ITEMS LIST

SECTION I. INTRODUCTION

C-1. SCOPE

a. This appendix lists expendable and durable items needed to operate and maintain the Demolition Materials, This listing is for information only and is not authority to requisition the listed items. These items are authorized to you by CTA 50-970, Expendable Items (except Medical, Class V Repair Parts, and Heraldic items).

b. Expendable and Durable item supplies should be requisitioned through normal supply channels to comply with maintenance requirements.

C-2. EXPLANATION OF COLUMNS

a. Column (1) - Item number. This number is assigned to the entry in the listing for referencing when required.

b. Column (2) - Level. This column identifies the lowest level of maintenance that requires the listed item.

O - Unit Maintenance
F - Direct Support Maintenance
H - General Support Maintenance

c. Column (3) - National Stock Number. This is the national stock number (NSN) assigned to the item; use it to request or requisition the item.

d. Column (4) - Description. Indicates the federal item name and, if required, a description to identify the item. The last line for each item indicates the Commercial and Government Entity Code (CAGEC) in parentheses followed by the part number.

e. Column (5) - Unit of Measure (U/M)/Unit of Issue (U/I). This measure is expressed by a two-character alphabetical abbreviation (i.e., EA, IN, PR). If the unit of measure differs from the unit of issue as shown in the Army Master Data File (AMDF), requisition the lowest unit of issue that will satisfy your requirements.

SECTION II. EXPENDABLE AND DURABLE ITEMS LIST

(1) Item Number	(2) Level	(3) National Stock Number	(4) Description	(5) (U/M)/ (U/I)
1	O	6810-00-184-4796	ACETONE, TECHNICAL: 5 gallon can (81348) O-A-51	CN
2	O	6810-00-543-7415	ALCOHOL, DENATURED: Grade III (81348) O-E-760	GL
3	O	8135-00-282-0565	BARRIER MATERIAL, WATER VAPOR PROOFED, FLEXIBLE: 200-yd roll, 36 in. wide, class 1 (81349) MILB131	RO
4	O	7920-00-255-5135	BRUSH, WIRE, SCRATCH: Beryllium copper alloy, curved handle, 14 in. x .9375 in. block, 6 in. x 1.125 min in. wire brush (81348) HB178	EA
5	O	7920-00-269-0933	BRUSH, WIRE, SCRATCH: Beryllium copper alloy, straight handle, 7 in. x 1 in. block (81348) HB178	EA
6	O	8020-00-597-5301	BRUSH, PAINT: Oval style, chiseled edge .875 in. w x 2.125 in. lg (81348) H-B-491	EA
7	O	7240-00-282-8411	CAN, FLAMMABLE WASTE: (58536) A-A-1674	EA
8	O	8030-00-290-5141	COATING COMPOUND, BITUMINOUS SOLVENT TYPE: Type 2 (81349) MIL-C-450	GL
9	O	8030-00-664-7105	COATING COMPOUND, BITUMINOUS, SOLVENT TYPE: TYPE I (81349) MIL-C-450	GL
10	O	7930-00-249-8036	DETERGENT, GENERAL PURPOSE: Powder, 5 lb. container (58536) A-A-1376	CO

(1) Item Number	(2) Level	(3) National Stock Number	(4) Description	(5) (U/M)/ (U/I)
11	O	8010-00-297-2122	ENAMEL: Black, No. 37038 (81348) TT-E-516	GL
12	O	8010-00-297-2119	ENAMEL: Blue, No. 35109 (81348) TT-E-516	GL
13	O	8010-00-297-2116	ENAMEL: Olive drab, No. 34088, 1 gal (81348) TT-E-516	GL
14	O	8010-00-297-2113	ENAMEL: Olive drab, No. 34088, 5 gal pail (81348) TT-E-516	CN
15	O	8010-00-848-9272	ENAMEL: Olive drab, No. 34088, lusterless, spray can (81348) TT-E-516	PT
16	O	8010-01-088-0096	ENAMEL: Orange, No. 32246 (81348) TT-E-515	QT
17	O	8010-00-297-2111	ENAMEL: White, No. 37875 (81348) TT-E-516	GL
18	O	8010-00-878-5761	ENAMEL: White, No. 37875, spray can (81348) TT-E-516	PT
19	O	8010-00-297-2112	ENAMEL: Yellow, No. 33538 (81348) TT-E-516	GL
20	O	8415-00-682-6786	GLOVES, DISPOSABLE: Plastic overall	PR
21	O	8520-00-782-3509	HAND, CLEANER: paste, grade A (10266) DD10	CN
22	O	7510-00-161-0811	INK, MARKING STENCIL: Black, Fed Std 595, 37038 (58536) A-A-208	GL
23	O	7510-00-161-0815	INK, MARKING STENCIL: White No. 37875 (80244) A-A-208	GL
24	O	7510-00-161-0816	INK, MARKING STENCIL: Yellow No. 33538 (58536) A-A-208	GL

(1) Item Number	(2) Level	(3) National Stock Number	(4) Description	(5) (U/M)/ (U/I)
25	0	8010-00-721-9479	LACQUER: Orange, No. 12215 (83421) 8010-00-721-9479	PT
26	0	8010-00-584-3148	LACQUER: Orange, No. 12197, spray can (81348) TT-L-50	PT
27	0	8010-00-063-8967	LACQUER: Aluminum, No. 17178 (81349) MIL-L-11195	GL
28	0	9150-00-231-6689	LUBRICATING OIL, GENERAL PURPOSE: (81348) VVL800	QT
29	0	7520-00-973-1059	MARKER, TUBE TYPE: Black, felt chisel tip, pocket clip provided (81348) GG-M-00114	DZ
30	0	5315-00-889-2743	NAIL: Style 4, type 2, size 4, 1 1/2 in. (81348) FF-N-105	PG
31	0	5315-00-889-2744	NAIL: Style 4A, type II, 2 in. (81348) FF-N-105	PG
32	0	8030-00-244-1033	NEAT'S FOOT OIL: 25 deg F pour point (81348) CN200TYPEI	GL
33	0	5350-00-271-7930	PAPER, ABRASIVE: (81348) P-P-105	PG
34	0	7920-00-205-1711	RAG, WIPING: Cotton, unbleached, mixture, 50 lb bale (64067) 7920-00-205-1711	BE
35	0	5340-00-491-7632	SEAL, ANTIPIRFERAGE METALLIC: 0.5 dia, 0.125 in. thk (96906) MS51938-5	EA
36	0	8135-00-239-5291	SEAL, STRAPPING: 0.625 in. nominal w (81346) ASTM D 3953-87	BX

(1) Item Number	(2) Level	(3) National Stock Number	(4) (U/M)/ Description	(5) (U/I)
37	O	3439-00-273-3722	SOLDER, TIN ALLOY Corrosion-resistant wire solder with rosin flux core (81348) QQ-S-571	SL
38	O	9310-00-240-4737	STENCILBOARD: Oiled, 18-1/2 in. x 18-1/2 in. (81348) UU-S-625	SH
39	O	8135-00-281-4071	STRAPPING: Steel, 0.625 in. wide, 0.020 in. thick (81346) ASTM D 3953-87	CL
40	O	7510-00-198-5831	TAPE, PRESSURE SENSITIVE ADHESIVE: (53578) 3842G	RO
41	O	7510-00-551-9822	TAPE, PRESSURE-SENSITIVE ADHESIVE: Transparent cellophane 0.5 in. w., w/ dispenser (52170) 600 1/2 x 500 in.	RO
42	O	7510-00-266-6712	TAPE, PRESSURE SENSITIVE ADHESIVE: Masking (opaque), 1 in. w, 3 in. dia. core, 60 yd lg, type 1 (19203) 8783476	RO
43	O	7510-00-266-6710	TAPE, PRESSURE SENSITIVE ADHESIVE: Masking, 2 in. w, 60 yd lg (18876) 802563	RO
44	O	7510-00-266-6715	TAPE, PRESSURE SENSITIVE ADHESIVE: 2 in. w, clear 60 yd lg (52170) 351	RO
45	O	7510-00-266-5016	TAPE, PRESSURE SENSITIVE ADHESIVE: Lusterless; water resistant (opaque); olive drab; 2.0 in. w., 60 yd lg (81348) PPP-T-60	RO
46	O	8010-00-242-2089	THINNER, PAINT PRODUCTS: Type 1 (81348) TT-T-291 TY 1	GL
47	O	8010-00-160-5794	THINNER, PAINT PRODUCTS: (81348) TT-T-306	GL

(1) Item Number	(2) Level	(3) National Stock Number	(4) (U/M)/ Description	(5) (U/I)
48	0	6810-00-664-0388	TRICHLOROETHANE, TECHNICAL: Liquid, Type I (81346) ASTM D4126	C N
49	0	5350-00-242-4405	WOOL, METALLIC: Steel, Type 2, 1 lb roll (58536) A-A-1043	LB

APPENDIX D PACKING MATERIALS, ACCESSORIES, AND TOOLS

Section I. INTRODUCTION

D-1. Scope

This appendix lists packing materials, accessories, and tools required for the performance of organizational maintenance for Demolition Materials.

D-2. General

This appendix is divided into the following sections:

a. Section II - Packing Materials. A list of packing materials authorized for the performance of maintenance at the organizational level.

b. Section III - Special Packing Tools List. A list of special tools and accessories authorized for the performance of maintenance at the organizational level.

D-3. Explanation of Columns

The following provides an explanation of columns in Section II and III.

a. Part Number (Drawing Number). Indicates the primary number used by the manufacturer which controls the design and characteristics of the item. Drawings can be obtained from originating source (see CAGE Code).

b. Commercial and Government Entity Code (CAGEC) - (Formerly known as Federal Supply Code for Manufacturers (FSCM)). A five-digit code used to identify the manufacturer, distributor, or Government agency/activity that supplies the item.

c. Figure Number. This column lists the number of the figure where the item is identified/located.

d. Description. Indicates the federal item name and any additional description of the item required.

Section II. PACKING MATERIALS

Part No. (Dwg No.)	CAGE Code	Figure No.	Description
9227581	19203		BOX,AMMUNITION: Wood, F/100 Charges, demolition block, TNT, 1/2 lb w/ priming adapters M1A4
8797739	19203		BOX,PACKING,AMMUNITION: wood, used for demolition charges
9227582	19203		BOX,PACKING,AMMUNITION: wood, used for 50 charge demolition block L pound TNT.
9227589	19203		BOX,PACKING,AMMUNITION: wood, charged shaped 15 lbs, M2A3; 2 ea per box
7549165	19203		BOX,PACKING,AMMUNITION: plywood, NN-P-530, group A, exterior, explosive mines
8861208	19203		BOX,PACKING,AMMUNITION: wood, used for charge, demolition, shaped, 15 lb, M2A4 or M2A3 (practice)
8876128	19203		BOX,PACKING,AMMUNITION: wood, used for charge, demolition, M118
9216715	19203		BOX,PACKING,AMMUNITION: wood, used for charge, demolition, roll M186
B4760-1	19203		PRIMER,PERCUSSION: Improved no. 3, carton and box, wood
9215527	19203		BOX,PACKING,AMMUNITION: for Destructor, ME, Universal, M10
9227602	19203		BOX,PACKING,AMMUNITION: wood, used for Firing Device, Pull Release Type, M3 w/trip wire
9311138	19203		BOX,WOOD,WIREBOUND: pkg, mkg, for box, multi-purpose, M142, ammo, M19A1
8822125	19203		BOX,PACKING,AMMUNITION: for fuse igniters, 10.250 in. nom wd, 18.437 in. nom lg, 10.688 in. nom dp, wood
8825213	19203		BOX,PACKING,AMMUNITION: wood, detonator, percussion, models M1A2 and M2A1
8835011	19203		BOX,PACKING,AMMUNITION: wood, used for igniter, blasting fuse, friction type M3A1
76-1-1497	19203		BOX,PACKING,ASSEMBLY: f/lighter, fuze, weather-proof, M2; consists of swivel assy, connector, filler, handle, hasp, hinge

Section II. PACKING MATERIALS (CONT'D)

Part No. (Dwg No.)	CAGE Code	Figure No.	Description
MS35190-236	96906		SCREW,MACHINE: rh, A39 flat countersunk, cd and cr pl, 6-32UNC-2A x .375
MS35206-233	96906		SCREW MACHINE: rh, A-23 PAN, cd and cr pl, 6-32UNC-2A x .875
MIL-T-16366	81349		SPLICE,CONDUCTOR: straight barrel all ends, COD, 14 AWG, uninsulated, .0625 in lg
MILB13136	81349		BATTERY, NONRECHARGEABLE: No. BA-245/U, 2.375 in. nom lg, 0.9 V
BA-2245/U	80058		BATTERY, NONRECHARGEABLE: No. BA-2245/U, 2.375 in. nom lg, 0.9 V, designed for use in arctic zones
801560	19203		BARRIER MATERIAL, WATER VAPOR PROOF: 200 yd lg, 36 in. w, 0.07 gm max, roll form

THIS PAGE INTENTIONALLY LEFT BLANK

By Order of the Secretary of the Army:

Official:

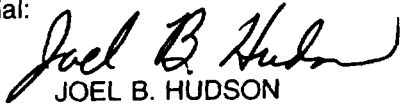

JOEL B. HUDSON

*Acting Administrative Assistant to the
Secretary of the Army*

01479

DENNIS J. REIMER
*General, United States Army
Chief of Staff*

Distribution:

To be distributed in accordance with DA Form 12-40-E, Block 0330, requirements for
TM 9-1375-213-34&P

FILL IN YOUR
UNIT'S ADDRESS

FOLD BACK

DEPARTMENT OF THE ARMY

OFFICIAL BUSINESS
PENALTY FOR PRIVATE USE \$300

POSTAGE AND FEES PAID
DEPARTMENT OF THE ARMY
DOD 314



TEAR ALONG PERFORATED LINE

Commander
US Army TACOM, Armament Research,
Development and Engineering Center
ATTN: AMSTA-AR-LSB
Picatinny Arsenal, NJ 07806-5000

